

## Assembly Instruction

# PATIO LOVESEAT GLIDER CHAIR

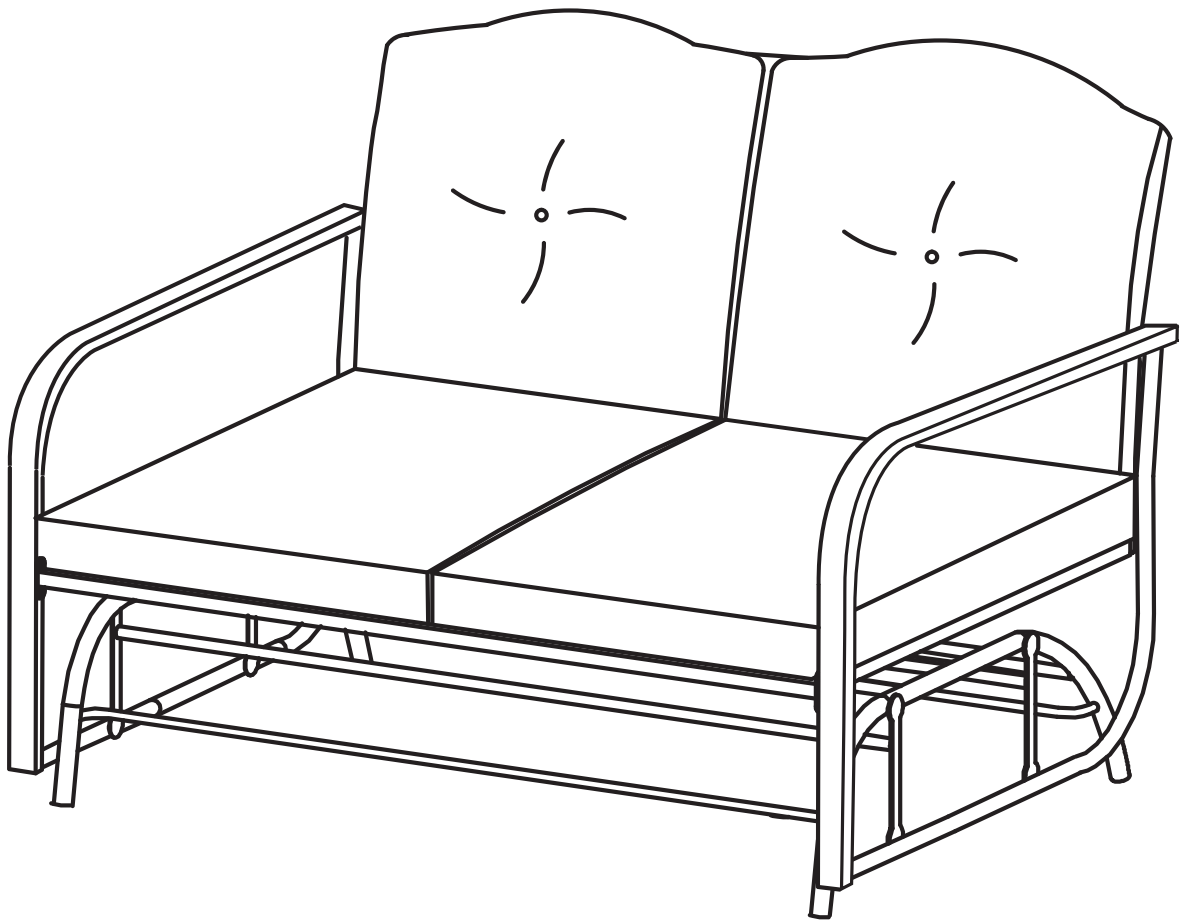

Carefully unpack and identify each component before beginning assembly. Before you begin, please refer to parts list to make sure that you have all parts. Please take care when assembling the unit and always place the parts on a clean, soft surface. If you require assistance with assembly or parts, please call 888-357-7263.

Get social with us and discover more about our products, tips and exclusive discounts!







**PRE-ASSEMBLY PREPARATION**



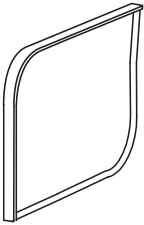
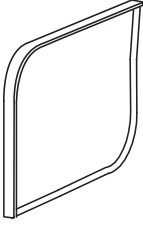
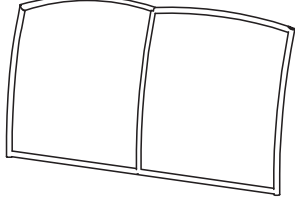
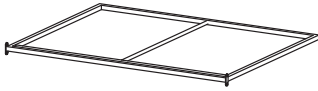
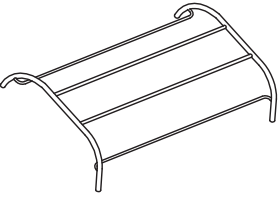



**WARNING!** DO NOT LET CHILDREN PLAY IN OR AROUND THE UNIT DUE TO THE POSSIBLE RISK OF FINGER ENTRAPMENT

- Please read through this instruction before beginning assembly.
- Two adults assembly is recommended.
- Clear out the space for assembly and lay out all parts base on Parts List, extra room will allow you to easily determine if all the pieces are present.
- Save all packing materials until assembly is complete to avoid accidentally discarding smaller parts or hardware.
- Keep small parts and pieces away from children until fully assembly.
- **Do not fully tighten the bolts until all have been inserted and hand tightened.**
- Please check for any loose screws and tighten them before use.

**PANEL AND FITTINGS IDENTIFICATION**

|   |  |  |   |
|---|--|--|---|
| <p>Right Armrest (A)</p>  <p>Qty: 1</p> | <p>Left Armrest (B)</p>  <p>Qty: 1</p>   | <p>Back Panel (C)</p>  <p>Qty: 1</p>    | <p>Seat Panel (D)</p>  <p>Qty: 1</p>    |
| <p>Base (E)</p>  <p>Qty: 1</p>         | <p>Conneting Rod (F)</p>  <p>Qty: 2</p> | <p>Seat Cushion (G)</p>  <p>Qty: 2</p> | <p>Back Cushion (H)</p>  <p>Qty: 2</p> |

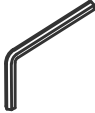
**HARDWARE LIST**

|  |  |   |  |
|--|--|---|--|
| <p>Bolt (I)</p>  <p>M6 x 25mm</p> <p>Qty: 8</p> | <p>Bolt (J)</p>  <p>M6 x 15mm</p> <p>Qty: 4</p> | <p>Bolt (K)</p>  <p>M6 x 40mm</p> <p>Qty: 7</p>         | <p>Washer (L)</p>  <p>Qty: 19</p> |
| <p>Plastic Cap (M)</p>  <p>Qty: 19</p>          | <p>Wrench (N)</p>  <p>Qty: 1</p>                | <p>Plastic Washer (O)</p>  <p>M6 x 2mm</p> <p>Qty: 8</p> |  |

**STEP-BY-STEP ASSEMBLY**

**STEP 1** Attach 2 pc short end of Connecting Rods (F) to Base (E) with Washer (L) and Bolt (I). Save bolt cap (M) until all parts have been connected and add after final tightening. If this step is completed correctly, the long end of connector bar (F) should hang down as shown in assembly picture.

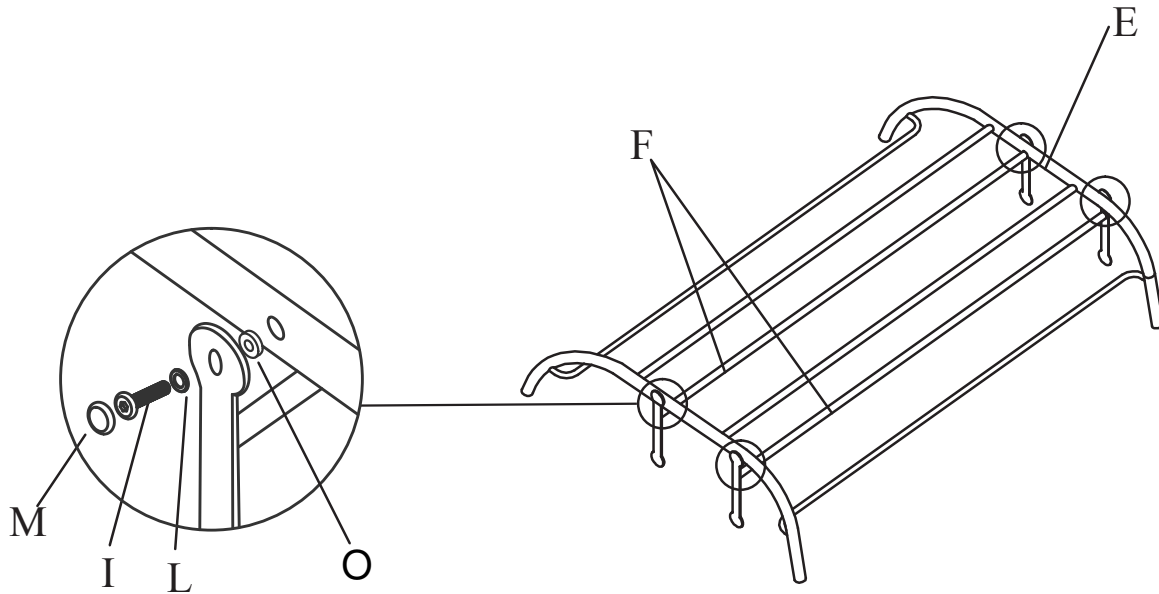

**STEP 2** Attach Back Panel (C) to Seat Panel (D) with Washer (L), Bolt (K) and Bolt Cap (M); Save bolt cap(M) until all parts have been connected and add after final tightening. During final assembly, when you are tightening all screws, the center screw in this step may not tighten as fully down as the other 2 end screws. This is not a defective issue. The center screw may remain a little higher due to the wrapped vinyl straps that are attached to the seat frame.

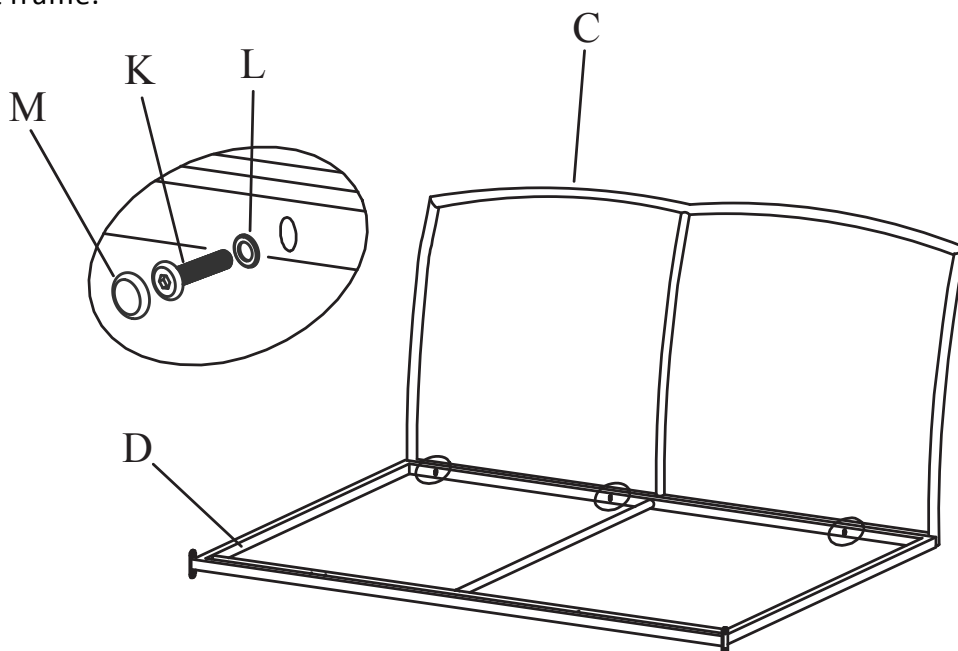

**STEP 3** NOTE: When attaching the arms, insert screws in opposite order to ensure hole lineup, as follows, in an "X" pattern per arm.--  
 Attach Right Armrest (A) and Left Armrest (B) to Back Panel (C) and Seat Panel (D) with Washer (L), Bolt (K), Bolt (J) and Bolt Cap (M); Save bolt cap (M) until all parts have been connected and add after final tightening.

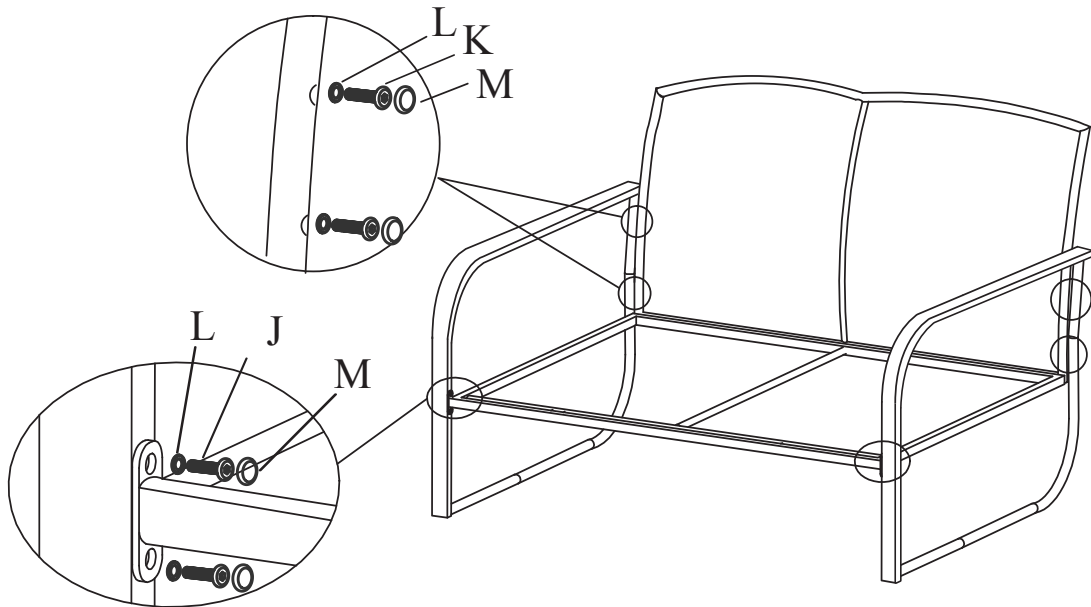

**NOTE: Bolt K is used for the back arm assembly.  
 Bolt J is used for the front arm assembly.**

**STEP 4:** Connect Right Armrest (A) and Left Armrest (B) to Conneting Rod (F) with Washer (L), Bolt (I) and Bolt Cap (M); Save bolt cap (M) until all parts have been connected and add after final tightening.

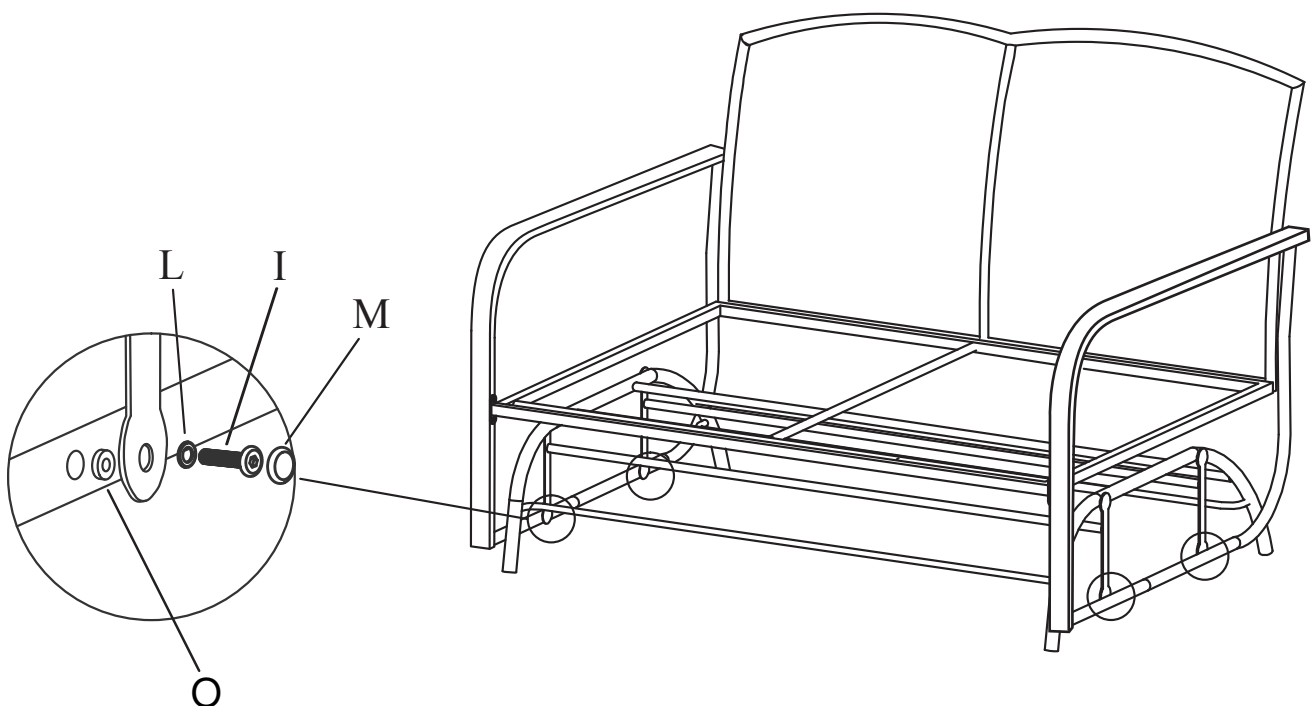

**STEP 5** Now tighten all screws using the locking wrench to ensure assembly is complete and secure. Once complete, use bolt cap(M) to cover all screw heads.

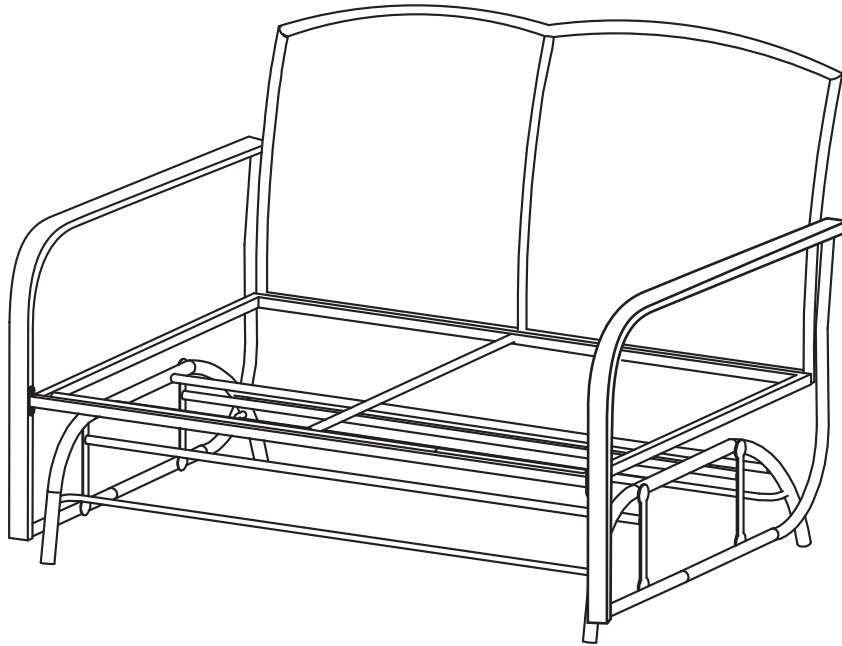

**STEP 6** Put on Seat Cushion (G) and Back Cushion (H). Please make sure all bolts are properly tightened before use.

