

Assembly Instruction

WINE RACK

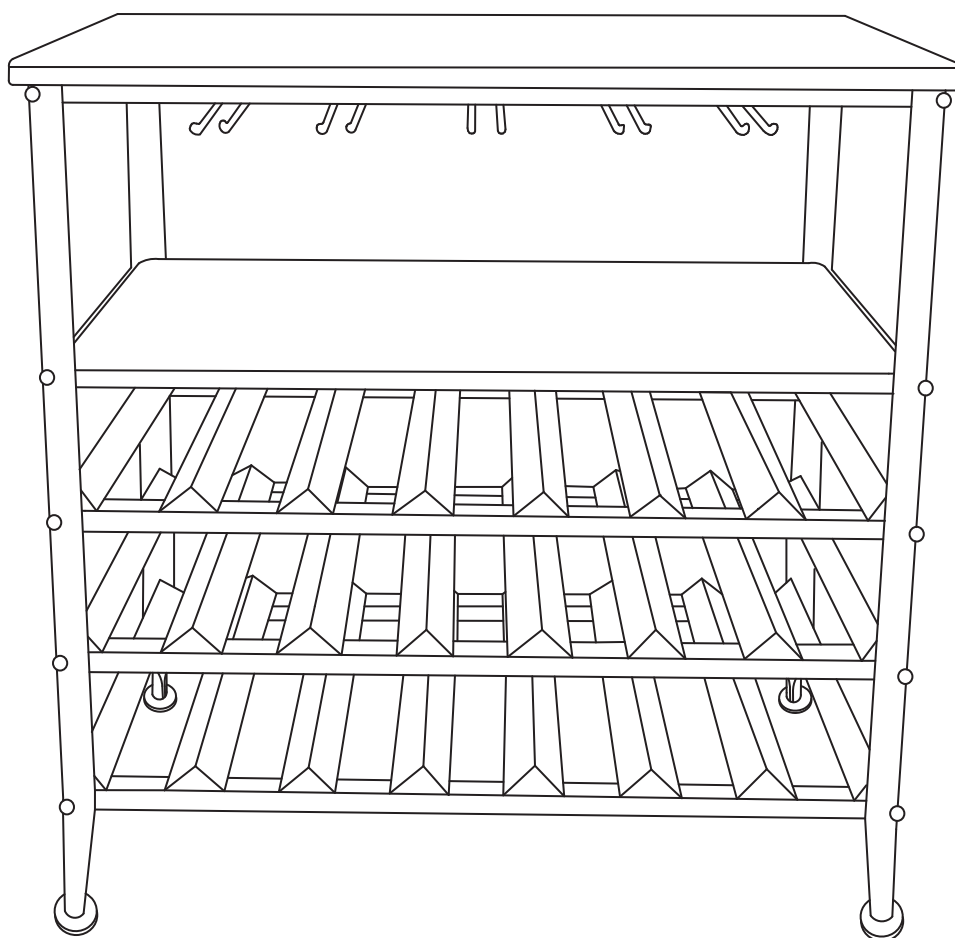

Carefully unpack and identify each component before beginning assembly. Before you begin, please refer to parts list to make sure that you have all parts. Please take care when assembling the unit and always place the parts on a clean, soft surface.

Get social with us and discover more about our products, tips and exclusive discounts!











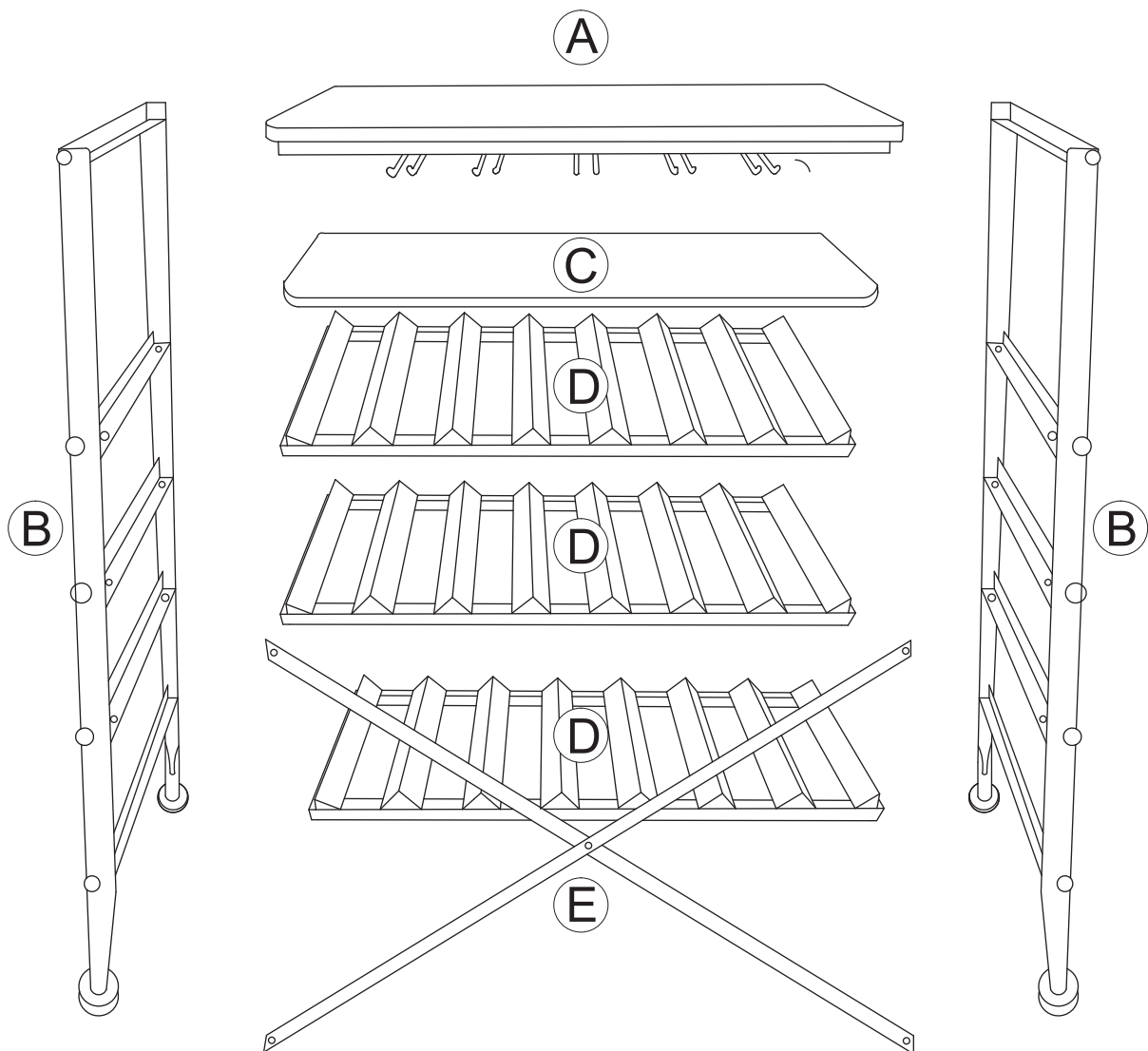





PRE-ASSEMBLY PREPARATION

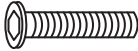

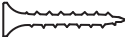
WARNING: MAXIMUM LOAD NOT EXCEED 55LBS ON SHELVES.

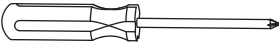
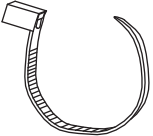
- **CAUTION:** Assembly will require at least 2 adults.
DO NOT use power tools. To prevent serious injury or death, this product is equipped with a wall anchoring system. Before this product can be used, the wall anchoring system must be installed as directed in the assembly instructions.
- **CARE AND CLEANING:** DO NOT scratch or chip the finish. DO NOT use abrasive chemicals for cleaning. Clean with mild soap on a soft rag. Rinse and dry thoroughly.
- **MAINTENANCE:** Check bolts/screws periodically and tighten if necessary.
- **WARNING:** DO NOT USE if this product become damaged, and/or components are broken or missing.
- **REMINDER:** Please DO NOT fully tighten all bolts until metal frame assembly is complete.

Explosive View



PARTS LIST			
<p>TOP PANEL (A)</p>  <p>Qty: 1</p>	<p>SIDE PANEL (B)</p>  <p>Qty: 2</p>	<p>FLAT SHELF (C)</p>  <p>Qty: 1</p>	<p>WINE RACK SHELF (D)</p>  <p>Qty: 3</p>
<p>REINFORCED POLE (E)</p>  <p>Qty: 1</p>			
HARDWARE LIST			
<p>ALLEN BOLT (F)</p>  <p>M6*15mm</p> <p>Qty: 20</p>	<p>BOLT LOCK (G)</p>  <p>Ø15*0.9mm</p> <p>Qty: 20</p>	<p>PHILLIPS SCREW (H)</p>  <p>Ø4*20mm</p> <p>Qty: 15</p>	<p>ALLEN WRENCH (I)</p>  <p>Qty: 1</p>
<p>SCREWDRIVER (J)</p>  <p>Qty: 1</p>	<p>ANTI-TIPPING STRIP (K)</p>  <p>5*270mm</p> <p>Qty: 1</p>	<p>WALL ANCHOR (L)</p>  <p>Ø8.5*30mm</p> <p>Qty: 1</p>	<p>PHILLIPS SCREW (M)</p>  <p>Ø4*40mm</p> <p>Qty: 1</p>
<p>STEEL PLATE (N)</p>  <p>12*12*27mm</p> <p>Qty: 2</p>			

REQUIRED HARDWARE IN THIS STEP 1 & 2			
NO.	DESCRIPTION	SKETCH	QTY
F	ALLEN BOLT		20PCS
G	BOLT LOCK		20PCS
I	ALLEN WRENCH		1PC

STEP 1

Attach 1 pc Side Panel (B) to the Top Panel (A), the Flat Shelf (C) and 3 pcs Wine Rack Shelves (D) by using 10 pcs Allen Bolt (F), 10 pcs Bolt Lock (G) and Allen Wrench (I).

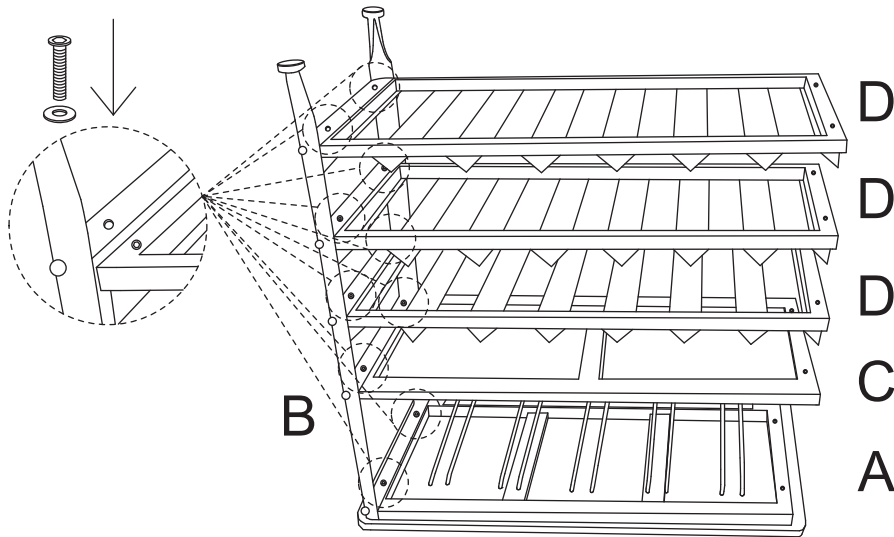

STEP 2

Attach 1 pc Side Panel (B) to the Top Panel (A), the Flat Shelf (C) and 3 pcs Wine Rack Shelves (D) by using 10 pcs Allen Bolt (F), 10 pcs Bolt Lock (G) and Allen Wrench (I).

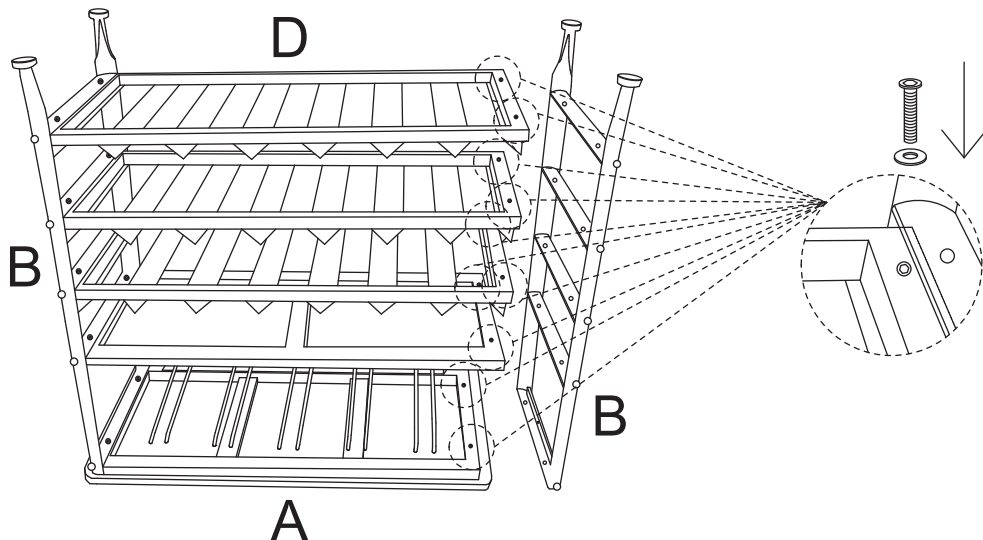

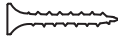
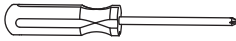
REQUIRED HARDWARE IN THIS STEP 3			
NO.	DESCRIPTION	SKETCH	QTY
H	PHILLIPS SCREW		10PCS
J	SCREWDRIVER		1PC

STEP 3

Using 10 pcs Phillips Screws (H) and Screwdriver (J) to fix the Side Panel (B), the Top Panel (A), the Flat Shelf (C) and 3 pcs Wine Rack Shelves (D) by two sides.

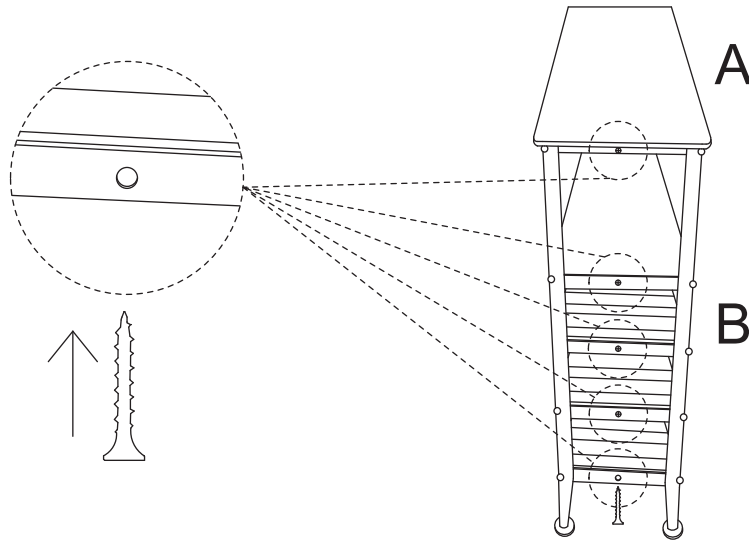

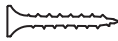
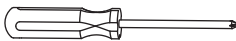



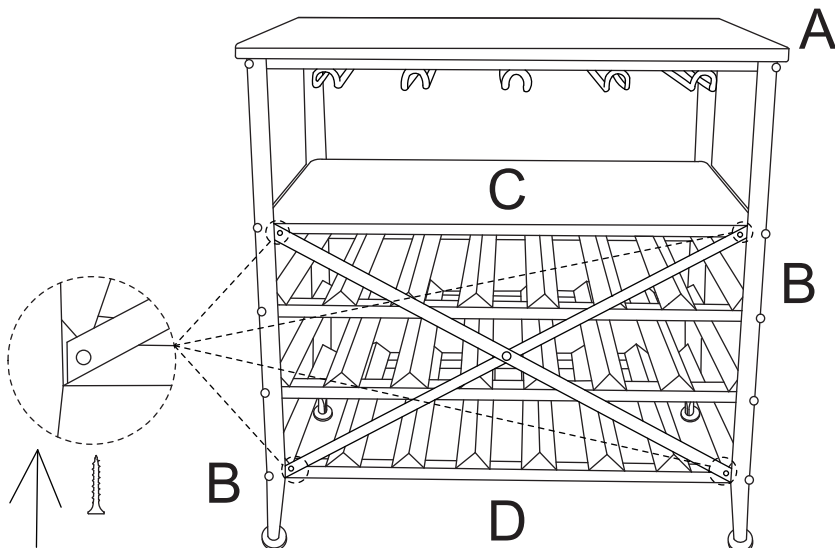

REQUIRED HARDWARE IN THIS STEP 4			
NO.	DESCRIPTION	SKETCH	QTY
H	PHILLIPS SCREW		4PCS
J	SCREWDRIVER		1PC

STEP 4

Using 4 pcs Phillips Screws (H) and Phillips Screwdriver (J) to fix the Reinforced Pole (E) to the Flat Shelf (C) and Bottom Wine Rack Shelves (D) .



REQUIRED HARDWARE IN THIS STEP 5			
NO.	DESCRIPTION	SKETCH	QTY
H	PHILLIPS SCREW Ø4*20mm		1PC
K	ANTI-TIPPING STRIP		1PC
L	WALL ANCHOR Ø8.5*30mm		1PC
M	PHILLIPS SCREW Ø4*40mm		1PC
N	STEEL PLATE		2PCS
J	PHILLIPS SCREW DRIVER		1PC

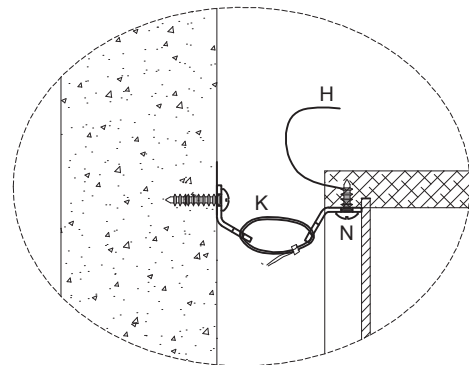
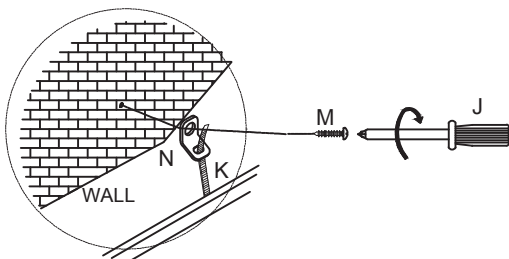
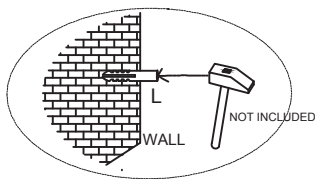
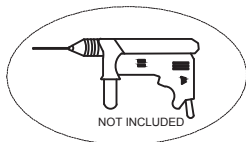

WALL

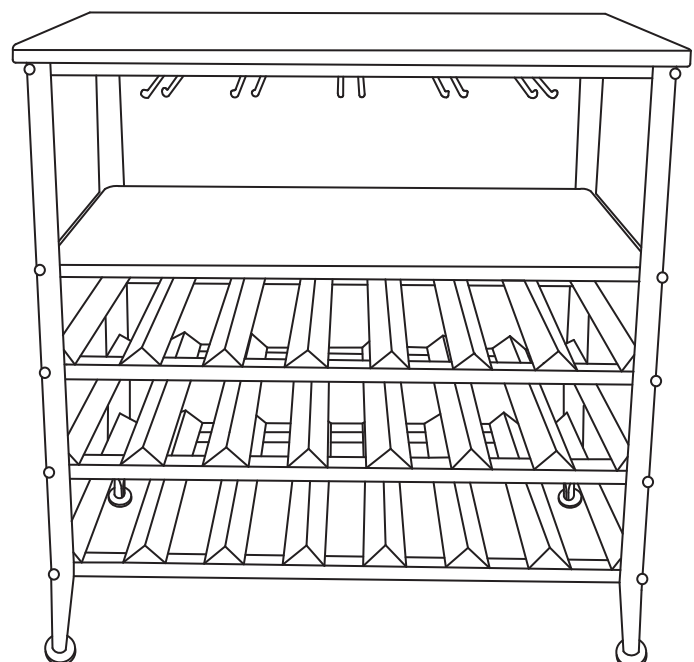

STEP 5

Attach steel plate (N) to top panel (A) with screw (H) using screwdriver. Place assembled unit in desired position. Mark position of steel plate (N) on wall and remove unit. Drill one hole on the wall and then put wall anchor (L) into the predrilled hole. Attach steel plate (N) to wall anchor (L) with screw (M) using screwdriver. Place unit back into position. Attach anti tipping strip (K) to steel plates (N) as shown.

STEP 6

