

# Assembly Instruction

## 3 SHELF BOOKCASE

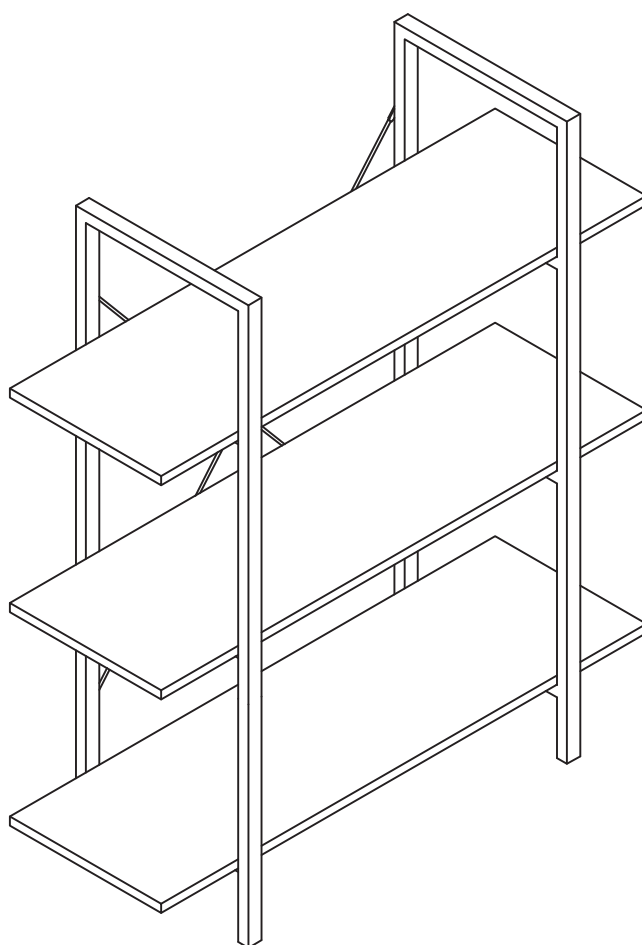

Carefully unpack and identify each component before beginning assembly. Before you begin, please refer to parts list to make sure that you have all parts. Please take care when assembling the unit and always place the parts on a clean, soft surface.

Get social with us and discover more about our products, tips and exclusive discounts!









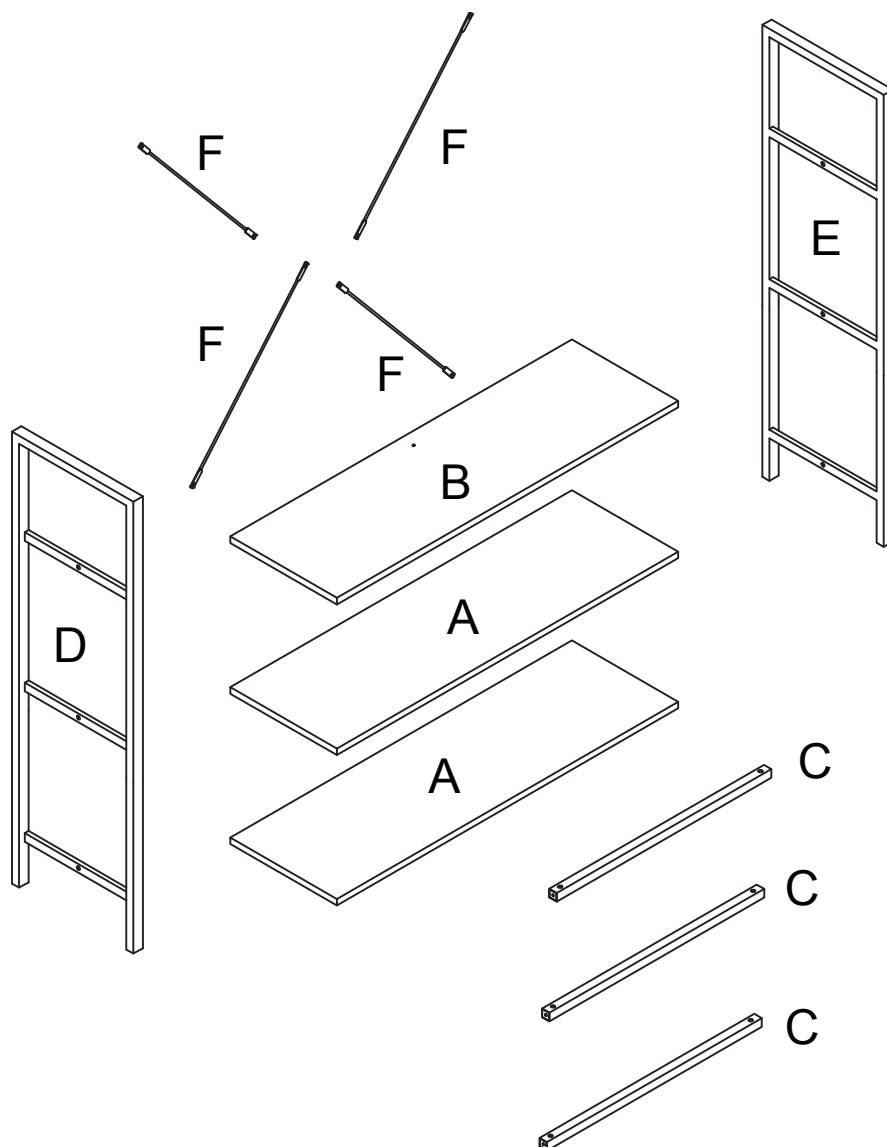

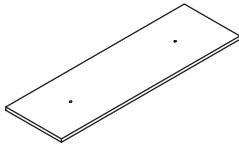
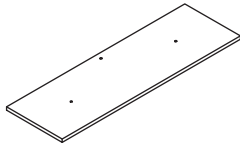
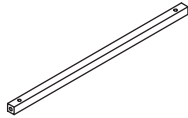
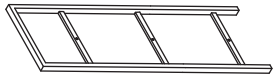
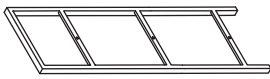
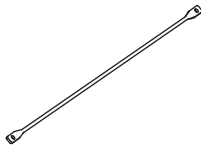

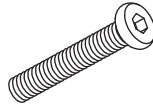

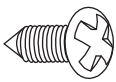
## PRE-ASSEMBLY PREPARATION

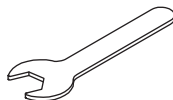
- **CAUTION:** Assembly will require at least 2 adults. DO NOT use power tools. Please inspect all items BEFORE assembly. If for any reason you need to return this item, please kindly return it in it's original packaging.
- **WARNING!**
  1. DO NOT let any sharp objects touch or rub the surface of the product.
  2. When assembling, do not let children play around the working area.
  3. DO NOT tighten all bolts and screws completely until the entire unit has been assembled and set up.
  4. DO NOT USE if this product become damaged, and/or components are broken or missing.
- **CARE AND CLEANING:** DO NOT scratch or chip the finish. DO NOT use abrasive chemicals for cleaning. Clean with mild soap on a soft rag. Rinse and dry thoroughly.
- **MAINTENANCE:** Please periodically check all fittings and re-tighten as necessary.

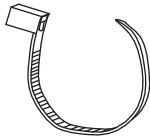
## Explosive View

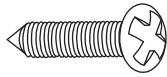
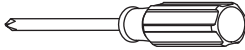





PARTS LIST			
<p>SHELF PANEL (A)</p>  <p>Qty: 2</p>	<p>TOP PANEL (B)</p>  <p>Qty: 1</p>	<p>SHELF CROSS BAR (C)</p>  <p>Qty: 3</p>	<p>LEFT METAL FRAME (D)</p>  <p>Qty: 1</p>
<p>RIGHT METAL FRAME (E)</p>  <p>Qty: 1</p>	<p>REAR CROSS BAR (F)</p>  <p>Qty: 4</p>		
HARDWARE LIST			
<p>ALLEN BOLT (1) M6*12mm</p>  <p>Qty: 1</p>	<p>ALLEN BOLT (2) M6*22mm</p>  <p>Qty: 6</p>	<p>ALLEN BOLT (3) M6*28mm</p>  <p>Qty: 6</p>	<p>ALLEN BOLT (4) M5*15mm</p>  <p>Qty: 1</p>
<p>PHILLIPS SCREW (5) 4*12mm</p>  <p>Qty: 4</p>	<p>NUT (6) M5</p>  <p>Qty: 1</p>	<p>ALLEN WRENCH (7) 4mm</p>  <p>Qty: 1</p>	<p>OPEN END WRENCH (8)</p>  <p>Qty: 1</p>
<p>L STEEL PLATE (9) 11*11*24mm</p>  <p>Qty: 2</p>	<p>ANTI-TIPPING STRIP (10) 5*200mm</p>  <p>Qty: 1</p>	<p>WALL ANCHOR (11) Ø8.5*30mm</p>  <p>Qty: 1</p>	<p>SCREW (12) 4*25mm</p>  <p>Qty: 1</p>
<p>NOT INCLUDED</p> 			

REQUIRED HARDWARE IN THIS STEP			
NO.	DESCRIPTION	SKETCH	QTY
2	ALLEN BOLT M6*22mm		6PCS
7	ALLEN WRENCH		1PC

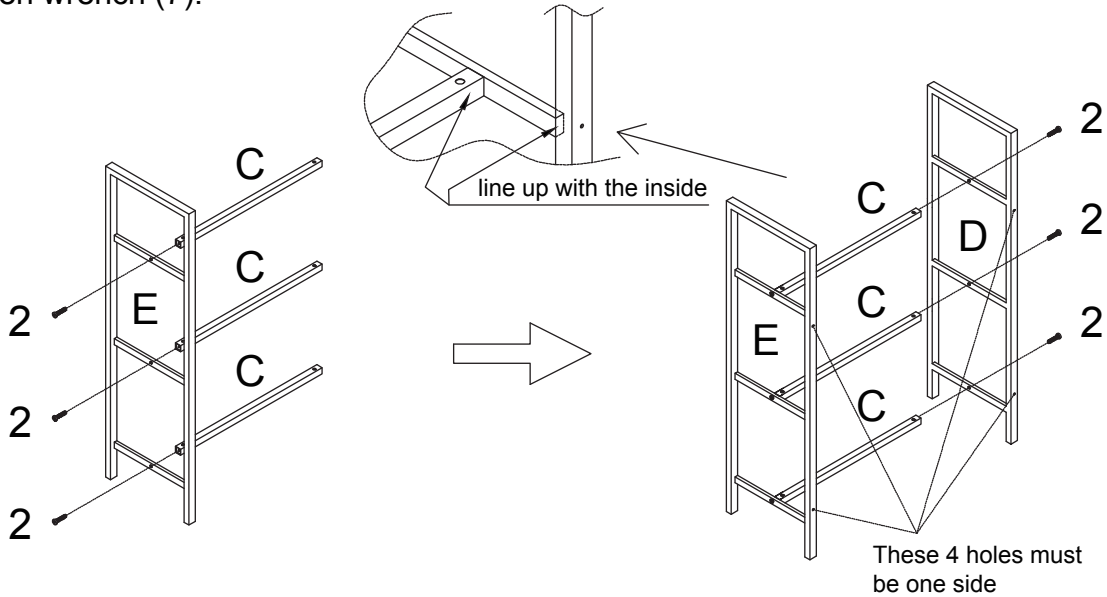
**STEP 1**

Assemble shelf cross bar (C) to right metal frame (E) and left metal frame (D) with allen bolt (2) using allen wrench (7).



REQUIRED HARDWARE IN THIS STEP			
NO.	DESCRIPTION	SKETCH	QTY
4	ALLEN BOLT M5*15MM		1PC
6	NUT M5		1PC
7	ALLEN WRENCH		1PC
8	OPEN END WRENCH		1PC

**STEP 2**

Assemble all rear cross bars (F) together at one end with Allen bolts (4) and nut (6) using Allen wrench (7) and Open end wrench (8). Fully tighten in this step.

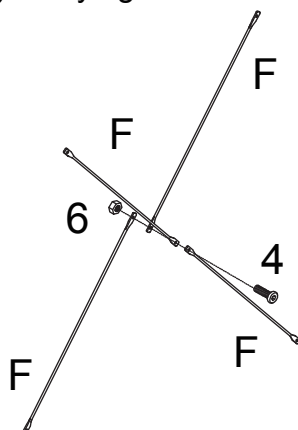

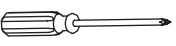

REQUIRED HARDWARE IN THIS STEP			
NO.	DESCRIPTION	SKETCH	QTY
5	PHILLIPS SCREW 4*12mm		4PCS
	PHILLIPS SCREW DRIVER		Not included

**STEP 3**

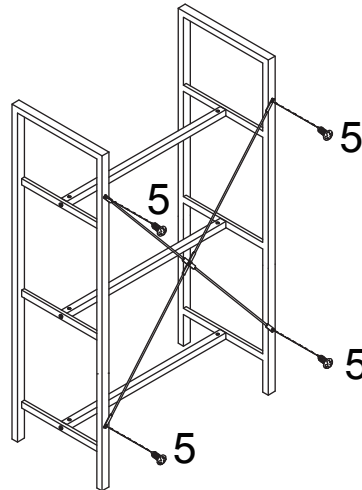
Attach the remaining ends of the rear cross bars to the back side of the assembled shelves with Phillips screws (5) . Fully tighten the screws by screwdriver (not included).







REQUIRED HARDWARE IN THIS STEP			
NO.	DESCRIPTION	SKETCH	QTY
3	ALLEN BOLT M6*30MM		6PCS
7	ALLEN WRENCH		1PC

**STEP 4**

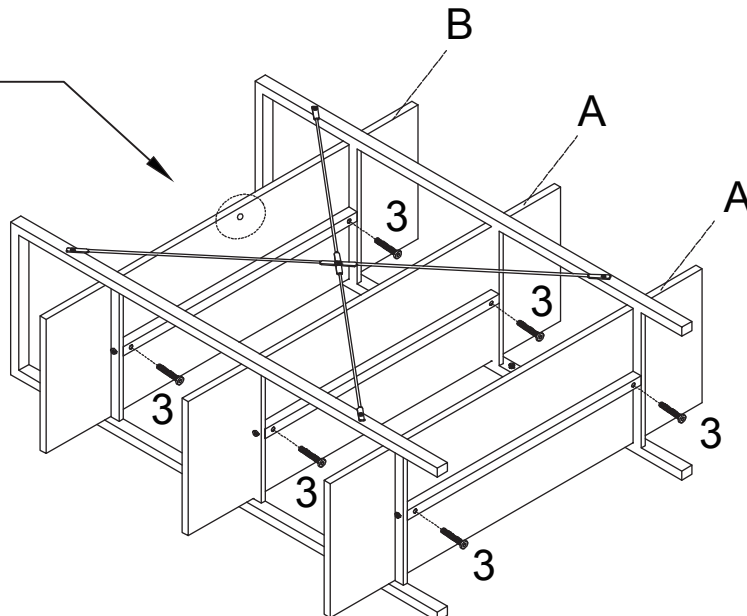
Assemble top panel (B) & shelf panel (A) on ready metal frame with Allen bolts (3) by using Allen wrench (7).

The hole on top panel (B) should be on the bottom and same side as x steel wire (F).





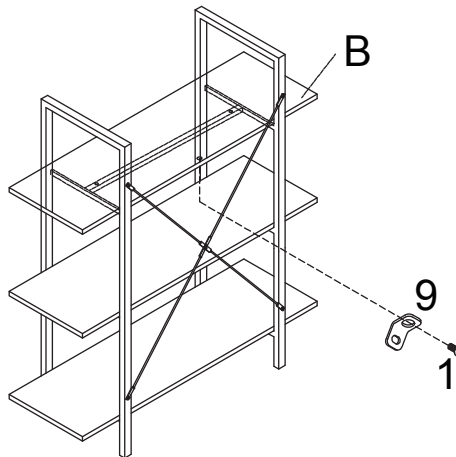

REQUIRED HARDWARE IN THIS STEP			
NO.	DESCRIPTION	SKETCH	QTY
1	ALLEN BOLT M6*12MM		1PC
9	STEEL PLATE		1PC
7	ALLEN WRENCH		1PC

**STEP 5**

Assemble steel plate (9) to top panel (B) with allen bolt (1) using Allen wrench (7).



REQUIRED HARDWARE IN THIS STEP			
NO.	DESCRIPTION	SKETCH	QTY
9	STEEL PLATE		1PC
10	ANTI-TIPPING STRIP		1PC
11	WALL ANCHOR Ø8.5*30MM		1PC
12	SCREW M4*25MM		1PC

**STEP 6**

Drill one hole on the wall and then put wall anchor (11) into the pre-drilled hole. Assemble steel plate (9) to the wall with screw (12) using screwdriver. Attach anti-tipping strip (10) to the steel plate (9) as shown.

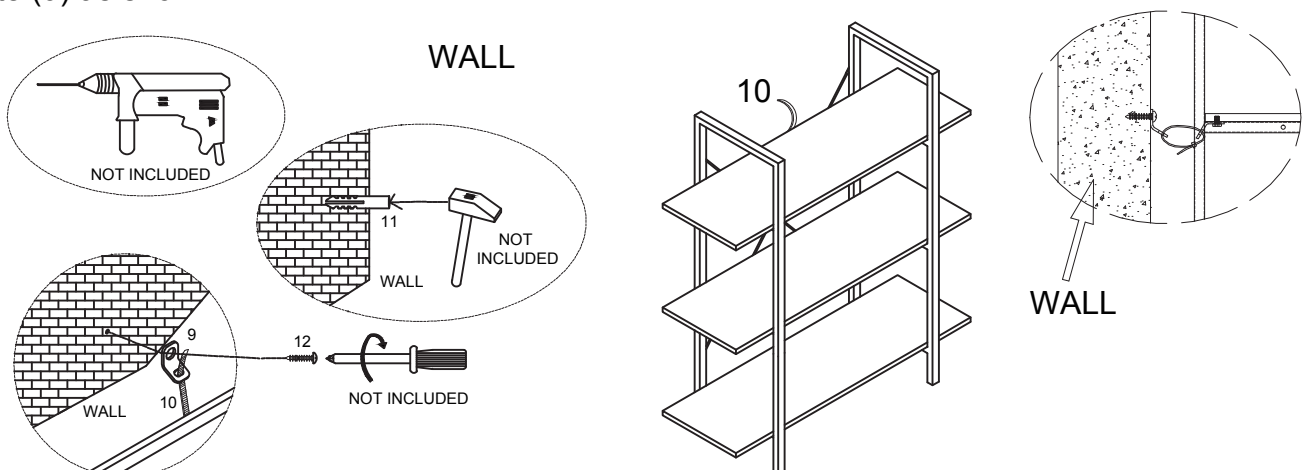

STEP 7

