

Assembly Instruction

BAR TABLE

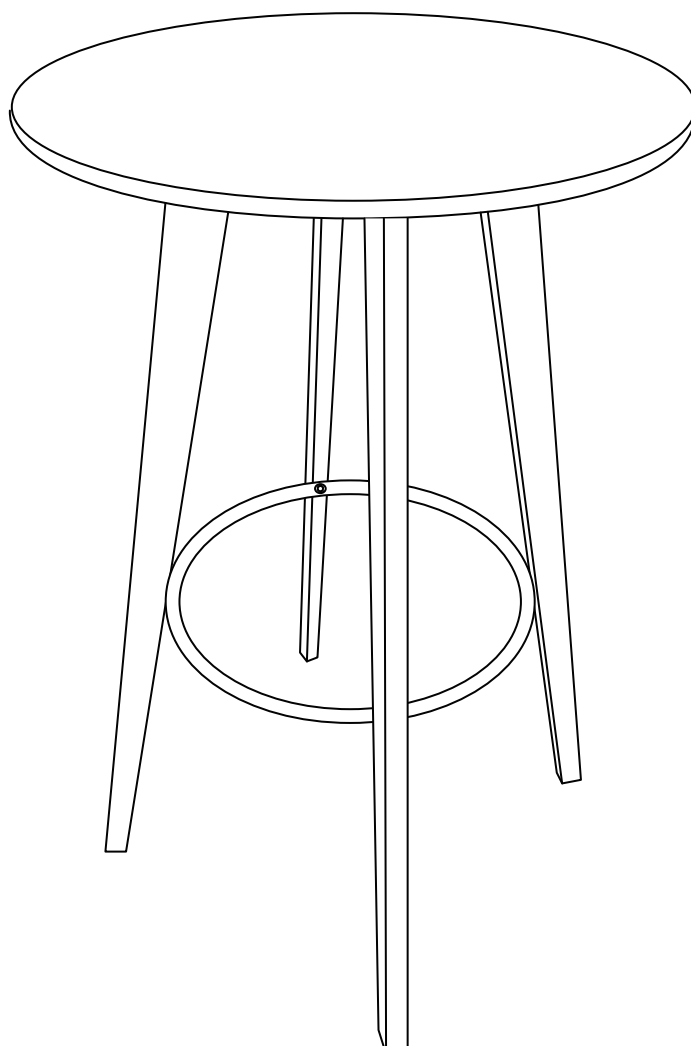

Carefully unpack and identify each component before beginning assembly. Before you begin, please refer to parts list to make sure that you have all parts. Please take care when assembling the unit and always place the parts on a clean, soft surface.

Get social with us and discover more about our products, tips and exclusive discounts!





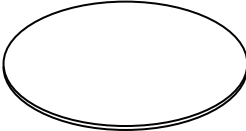
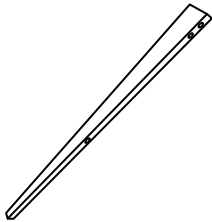
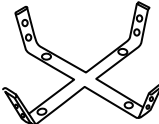
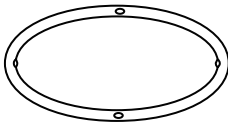

PRE-ASSEMBLY PREPARATION

- **CAUTION:** Assembly will require at least 2 adults. DO NOT use power tools. Please inspect all items BEFORE assembly. If for any reason you need to return this item, please kindly return it in it's original packaging.
- **WARNING!**
 1. DO NOT let any sharp objects touch or rub the surface of the product.
 2. When assembling, do not let children play around the working area.
 3. DO NOT tighten all bolts and screws completely until the entire unit has been assembled and set up.
 4. DO NOT USE if this product become damaged, and/or components are broken or missing.
- **CARE AND CLEANING:** DO NOT scratch or chip the finish. DO NOT use abrasive chemicals for cleaning. Clean with mild soap on a soft rag. Rinse and dry thoroughly.
- **MAINTENANCE:** Please periodically check all fittings and re-tighten as necessary.

PARTS LIST

<p>TABLE TOP (A)</p>  <p>Qty: 1</p>	<p>TABLE LEG (B)</p>  <p>Qty: 4</p>	<p>CONNECTING METAL (C)</p>  <p>Qty: 1</p>	<p>FOOTREST (D)</p>  <p>Qty: 1</p>
--	---	--	---

HARDWARE LIST

<p>SHORT ALLEN BOLT (E) M6 x 10MM</p>  <p>Qty: 4</p>	<p>MEDIUM ALLEN BOLT (F) M6 x 20MM</p>  <p>Qty: 8</p>	<p>LONG ALLEN BOLT (G) M6 x 30MM</p>  <p>Qty: 4</p>	<p>ALLEN KEY (H)</p>  <p>Qty: 1</p>
---	--	---	--

STEP 1

Attach the Connecting Metal (C) to the Table Top (A) by using Short Allen Bolt (E) and Allen Key (H) as shown in below diagram.

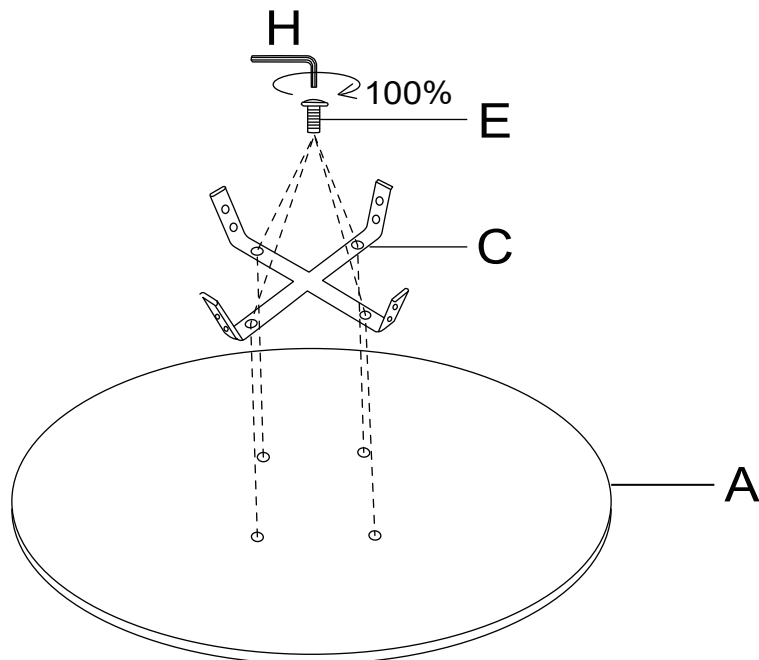

STEP 2

Attach the Table Leg (B) to the Connecting Metal (C) by using Medium Allen Bolt (F) and Allen Key (H) as shown in below diagram.

Reminder!!

Please do not tight bolt in this step.

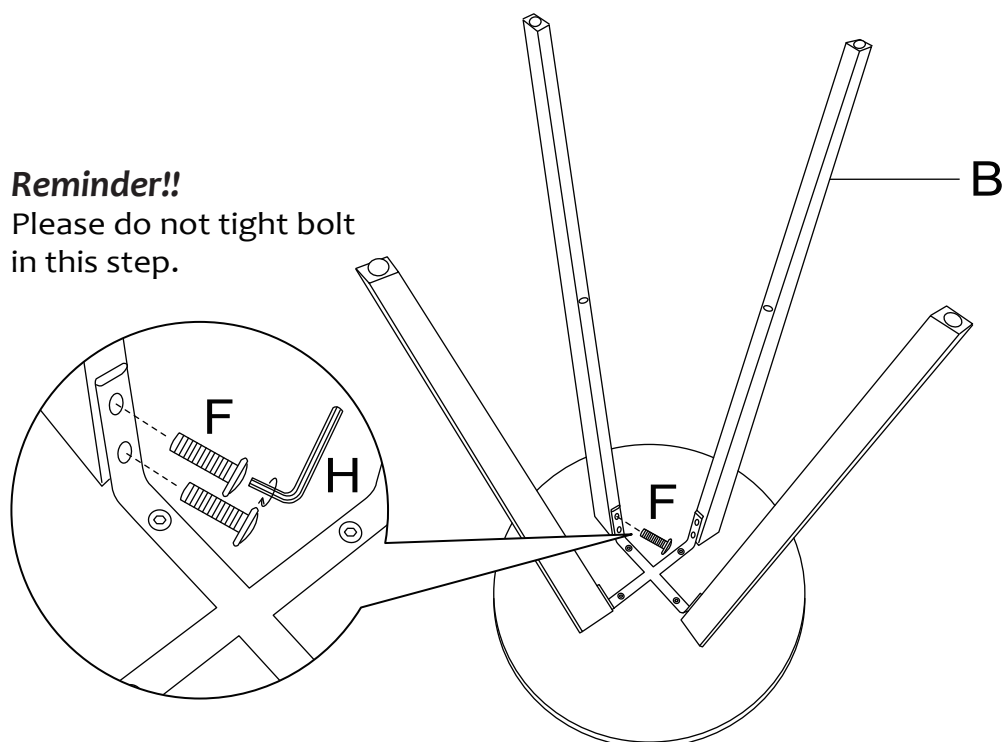

STEP 3

Attach the Footrest (D) to the Table Leg (B) by using Long Allen Bolt (G) and Allen Key (H) as shown in below diagram.

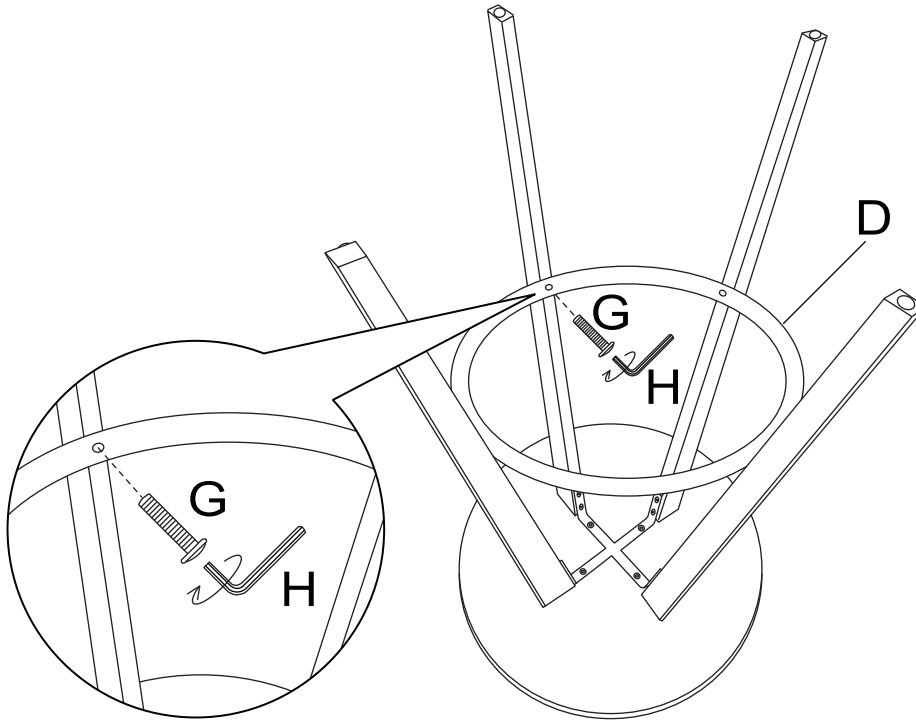

STEP 4

After initial assembly, the product may acclimate to its new environment. Please ensure all screws are still securely tightened.

