

Assembly Instruction

BAR STOOL

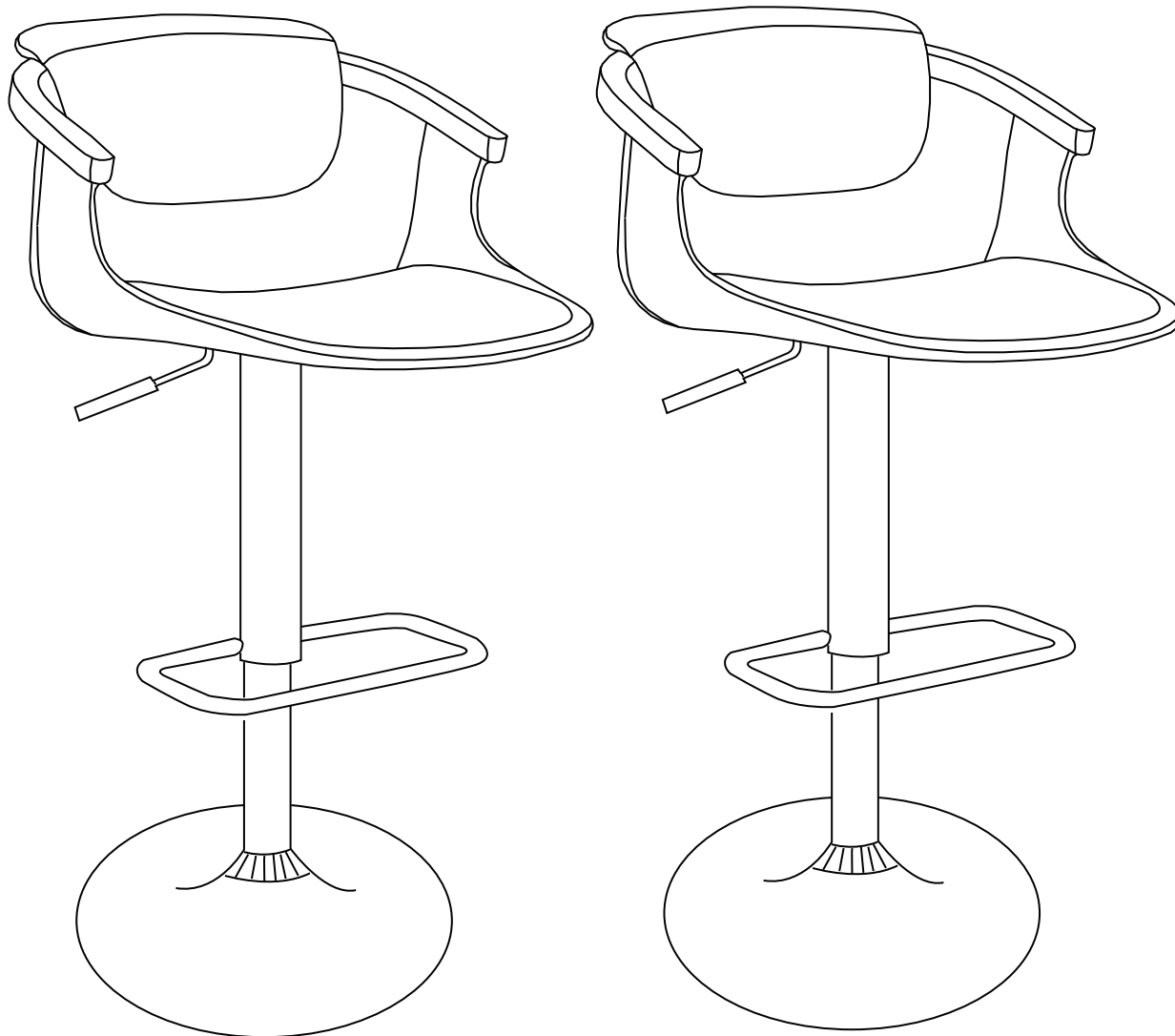

Carefully unpack and identify each component before beginning assembly. Before you begin, please refer to parts list to make sure that you have all parts. Please take care when assembling the unit and always place the parts on a clean, soft surface.





Get social with us and discover more about our products, tips and exclusive discounts!

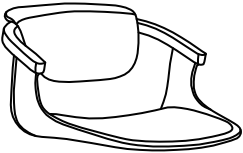
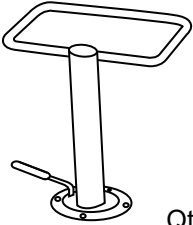
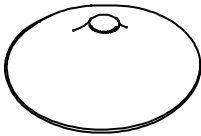
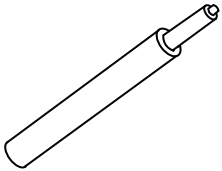

PRE-ASSEMBLY PREPARATION

- **CARE AND CLEANING:** DO NOT scratch or chip the finish. DO NOT use abrasive chemicals for cleaning.
- **MAINTENANCE:** Check bolts/screws periodically and tighten them if necessary.
- **WARNING:** DO NOT USE if this product become damaged, and/or components are broken or missing.
- **REMINDER:** DO NOT fully tighten all bolts until assembly is completely finished.

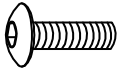
PARTS LIST

<p>SEAT (A)</p>  <p>Qty: 2</p>	<p>LEG (B)</p>  <p>Qty: 2</p>	<p>BASE (C)</p>  <p>Qty: 2</p>	<p>GAS LIFT (D)</p>  <p>Qty: 2</p>
<p>CAP (E)</p>  <p>Qty: 2</p>			
<p>HARDWARE LIST (one set in a plastic bag)</p>			
<p>ALLEN BOLT (F)</p>  <p>M6 x 20MM</p> <p>Qty: 8</p>	<p>ALLEN WRENCH (G)</p>  <p>Qty: 2</p>		

- **Kindly Reminder:** Two bags of hardware separately inside the carton.
One bag for one stool to assemble.

STEP 1

Insert the Gas Lift (D) and Cap (E) to the Base (C).

Warning!

Please remove the plastic cap before assembly.

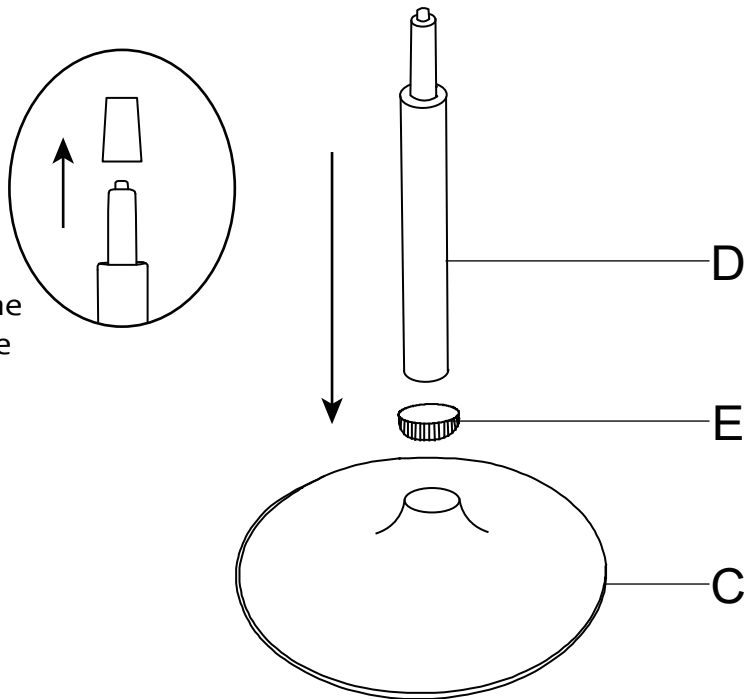

STEP 2

Attach the Leg (B) to the Seat (A) by using Allen Bolt (F) and Allen Wrench (G).

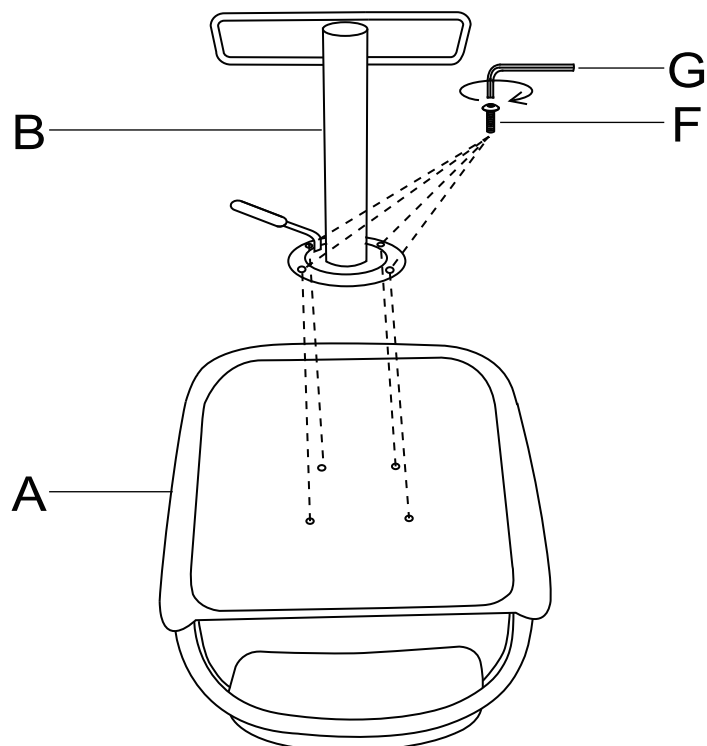

STEP 3

Insert the Leg (B) to the Gas Lift (D) of the base Part as shown below.

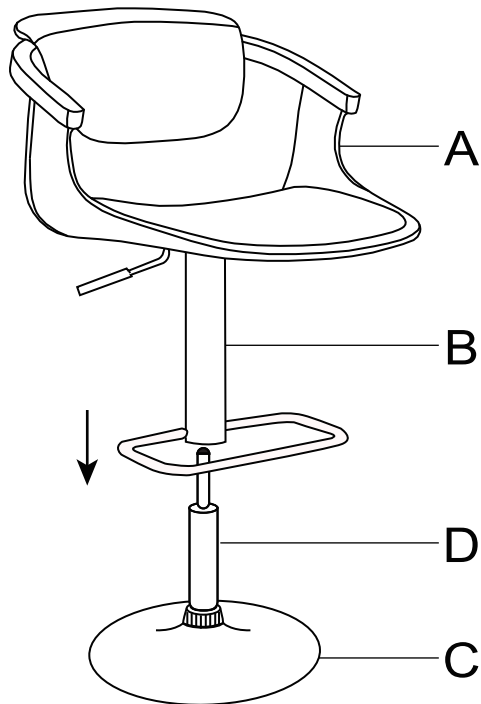

After initial assembly, the product may acclimate to its new environment. Please ensure all screws are still securely tightened.

