

Assembly Instruction

OFFICE CHAIR / DESK CHAIR



Carefully unpack and identify each component before beginning assembly. Before you begin, please refer to parts list to make sure that you have all parts. Please take care when assembling the unit and always place the parts on a clean, soft surface.





Get social with us and discover more about our products, tips and exclusive discounts!

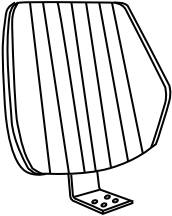
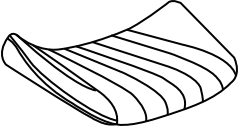
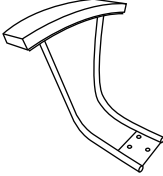
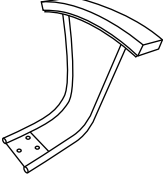
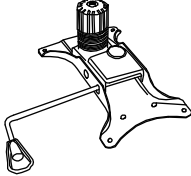
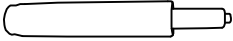
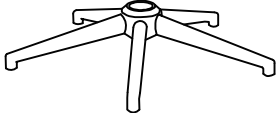

PRE-ASSEMBLY PREPARATION

- **CARE AND CLEANING:** DO NOT scratch or chip the finish. DO NOT use abrasive chemicals for cleaning.
- **MAINTENANCE:** Check bolts/screws periodically and tighten them if necessary.
- **WARNING:** DO NOT USE if this product become damaged, and/or components are broken or missing.
- **REMINDER:** DO NOT fully tighten all bolts until assembly is completely finished.

PARTS LIST

<p>BACKREST (A)</p>  <p>Qty: 1</p>	<p>SEAT (B)</p>  <p>Qty: 1</p>	<p>LEFT ARMREST (C)</p>  <p>Qty: 1</p>	<p>RIGHT ARMREST (D)</p>  <p>Qty: 1</p>
<p>SEAT PLATE (E)</p>  <p>Qty: 1</p>	<p>GAS LIFT (F)</p>  <p>Qty: 1</p>	<p>BASE (G)</p>  <p>Qty: 1</p>	<p>WHEEL (H)</p>  <p>Qty: 5</p>
<p>HARDWARE LIST</p>			
<p>LONG BOLT (I)</p>  <p>M6 x 20MM</p> <p>Qty: 10</p>	<p>SHORT BOLT(J)</p>  <p>M6 x 18MM</p> <p>Qty: 4</p>	<p>ALLEN WRENCH (K)</p>  <p>Qty: 1</p>	

STEP 1

Attach the Left Armrest (C) and Right Armrest (D) to the Seat (B) by using Long Bolt (I) and Allen Wrench (K). Connect the Backrest (A) and Seat (B) by using Long Bolt (I) and Allen Wrench (K).

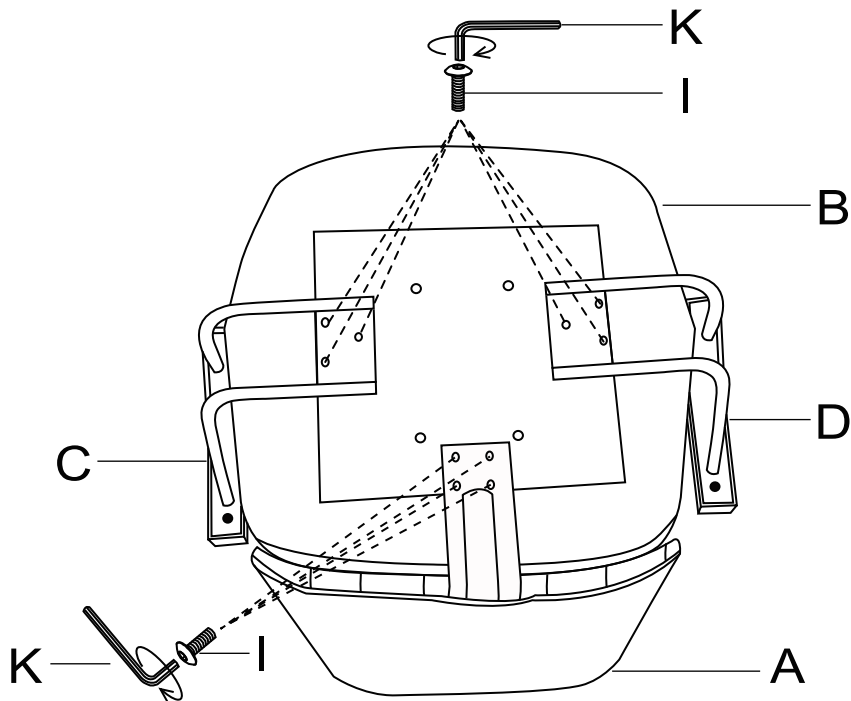

STEP 2

Attach the Seat Plate (E) to the Seat (B) by using Short Bolt (J) and Allen Wrench (K).

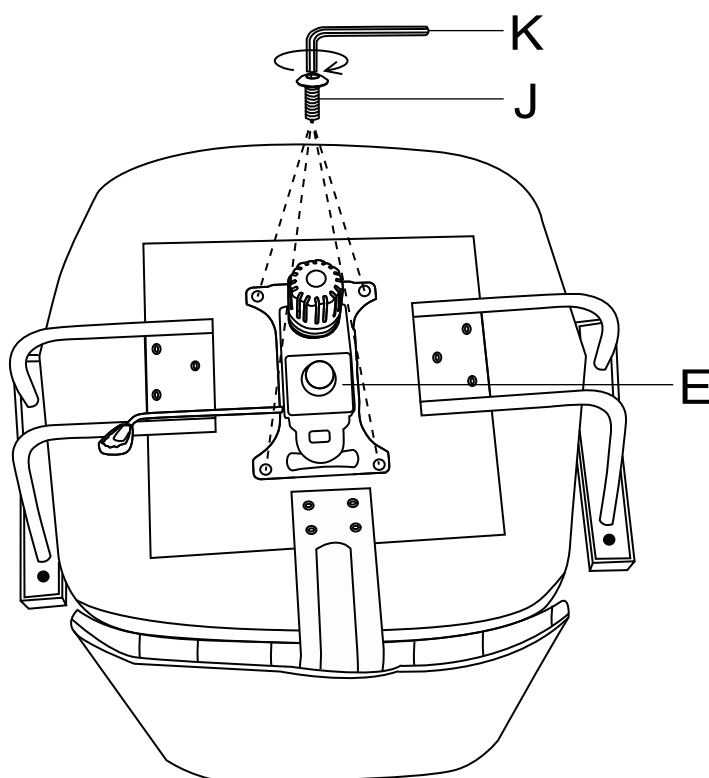

STEP 3

Insert the Gas Lift (F) to the Base (G), and snap in the Wheels (H) as shown below.

Warning!
Please remove the plastic cap before assembly.

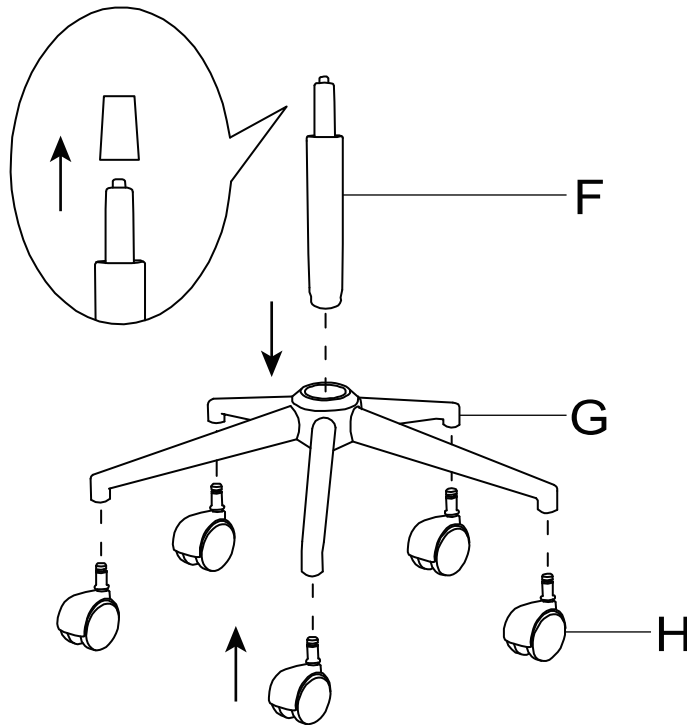

STEP 4

Insert the Seat Plate (E) to the Gas Lift (F) to as shown below.

After initial assembly, the product may acclimate to its new environment. Please ensure all screws are still securely tightened.

