

ASSEMBLY INSTRUCTION

ACCENT CHAIR

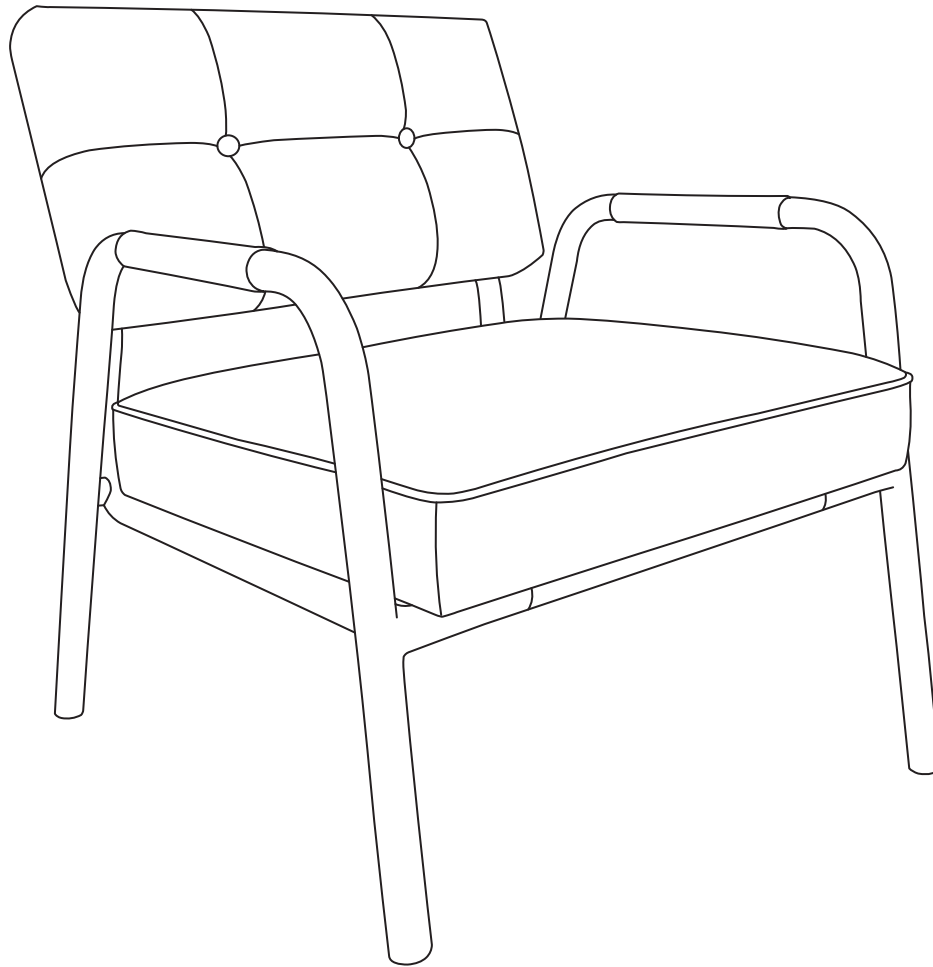







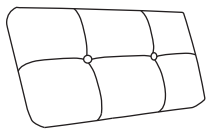

Please carefully unpack and identify each component before beginning assembly. Before you begin, please refer to parts list to make sure that you have all parts. Please take care when assembling the unit and always place the parts on a clean, soft surface. If you require assistance with assembly or parts, please call 888-357-7263.

Get social with us and discover more about our products, tips and exclusive discounts!

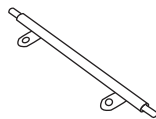

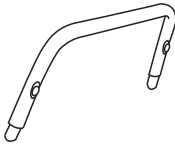
PRE-ASSEMBLY PREPARATION

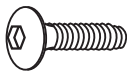
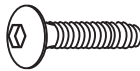
- **CAUTION:** Assembly will require at least 2 adults. DO NOT use power tools. Please inspect all items BEFORE assembly. If for any reason you need to return this item, please kindly return it in its original packaging.
- **WARNING!**
 1. DO NOT let any sharp objects touch or rub the surface of the product.
 2. When assembling, do not let children play around the working area.
 3. DO NOT tighten all bolts and screws completely until the entire unit has been assembled and set up.
 4. DO NOT USE if this product become damaged, and/or components are broken or missing.
- **CARE AND CLEANING:** DO NOT scratch or chip the finish. DO NOT use abrasive chemicals for cleaning. Clean with mild soap on a soft rag. Rinse and dry thoroughly.
- **MAINTENANCE:** Please periodically check all fittings and re-tighten as necessary.

| PARTS LIST | | | |
|---|---|--|---|
| <p>BACK (A)</p>  <p>Qty: 1</p> | <p>SEAT (B)</p>  <p>Qty: 1</p> | <p>SEAT FRAME CONNECTION (C)</p>  <p>Qty: 2</p> | <p>RIGHT SIDE FRAME (D)</p>  <p>Qty: 1</p> |
| <p>LEFT SIDE FRAME (E)</p>  <p>Qty: 1</p> | <p>BACK FRAME CONNECTION (F)</p>  <p>Qty: 1</p> | | |
| HARDWARE LIST | | | |
| <p>ALLEN BOLT (G) M6X20MM</p>  <p>Qty: 4</p> | <p>ALLEN BOLT (H) M6X25MM</p>  <p>Qty: 4</p> | <p>ALLEN BOLT (I) M6X45MM</p>  <p>Qty: 4</p> | <p>ALLEN WRENCH (J)</p>  <p>Qty: 1</p> |

STEP-BY-STEP ASSEMBLY

PLEASE CAREFULLY UNPACK AND IDENTIFY EACH COMPONENT BEFORE BEGINNING ASSEMBLY. BEFORE YOU BEGIN, PLEASE REFER TO PARTS LIST TO MAKE SURE THAT YOU HAVE ALL PARTS.

STEP 1 Connected the Right Side Frame (D) and the Left Side Frame (E) by using Seat Frame Connections (C) as shown in below diagram.

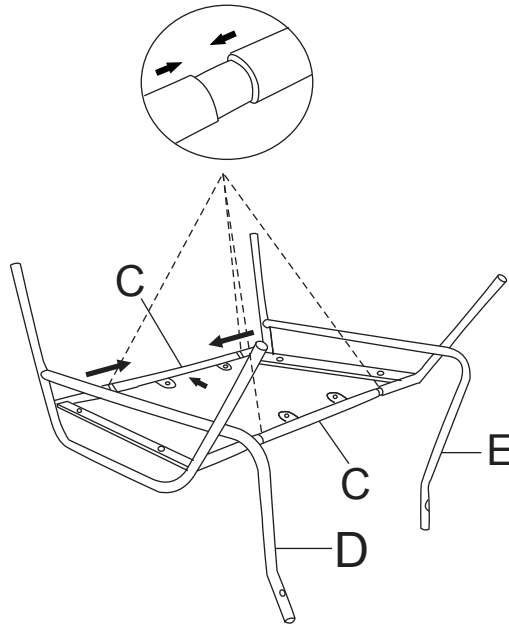

STEP 2 Attached the Seat (B) to the Right Side Frame (D) and Left Side Frame (E) by using Allen Bolt (H) and Allen Wrench (J) as shown in below diagram.
Please 80% tighten the bolts.

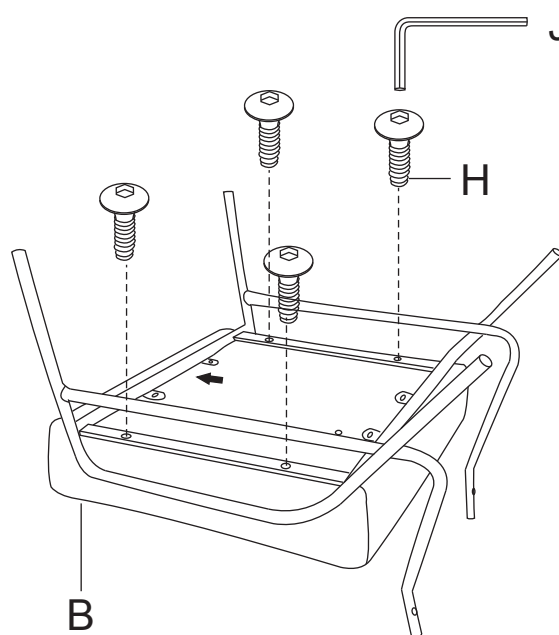

STEP 3 Attached the Seat (B) to the Seat Frame Connections (C) by using Allen Bolt (G) and Allen Wrench (J) as shown in below diagram. **Please 80% tighten the bolts.**

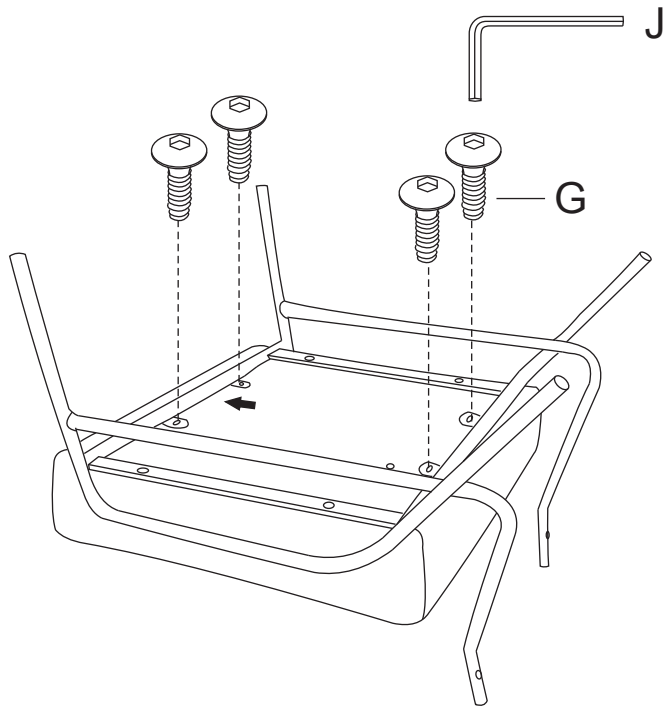

STEP 4 Attached the Back Frame Connection (F) to the Right Side Frame (D) and Left Side Frame (E) as shown in below diagram.

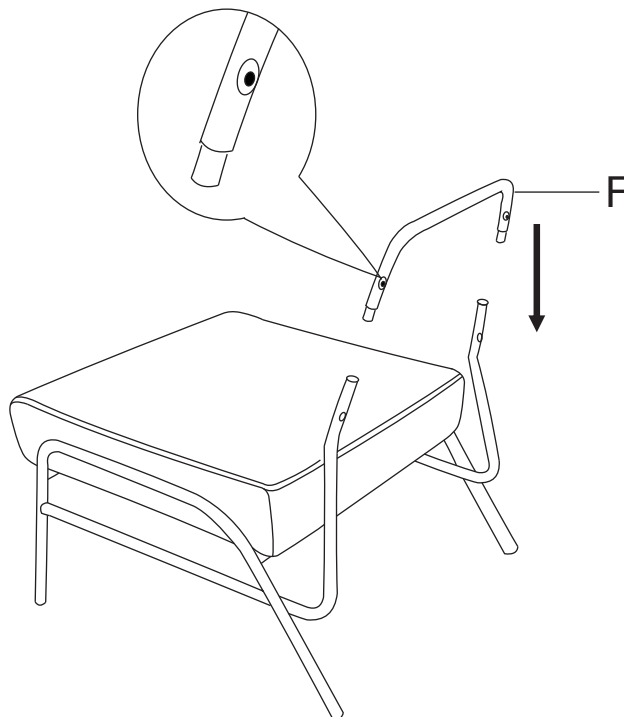

STEP 5 Attached the Back (A) to the Back Frame by using Allen Bolt (I) and Allen Wrench (J) as shown in below diagram. **Please 80% tighten the bolts.**

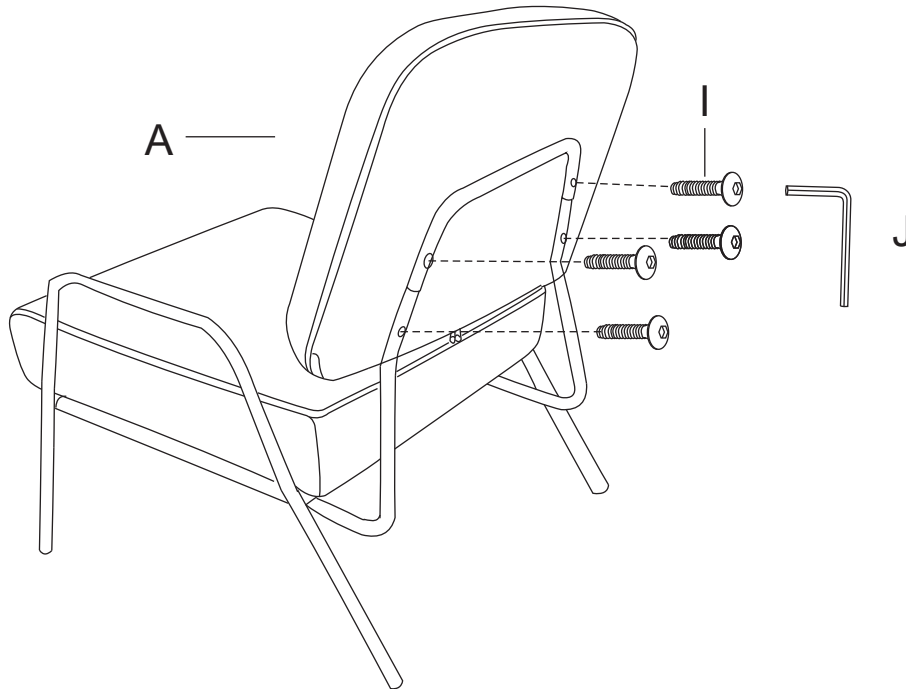

STEP 6 Please 100% tighten all Allen Bolts (G,H,I) completely by using Allen Wrench (J) . After initial assembly, the product may acclimate to its new environment. Please ensure all screws are still securely tightened.

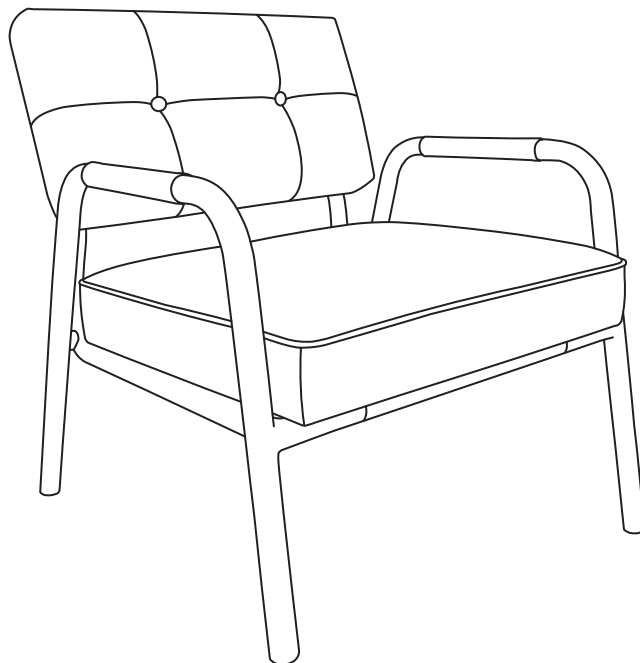

glit⁺home[®]

Glit⁺home ,LLC.

Toll free 888-357-7263

customerservice@glit⁺home.com