

Step 1

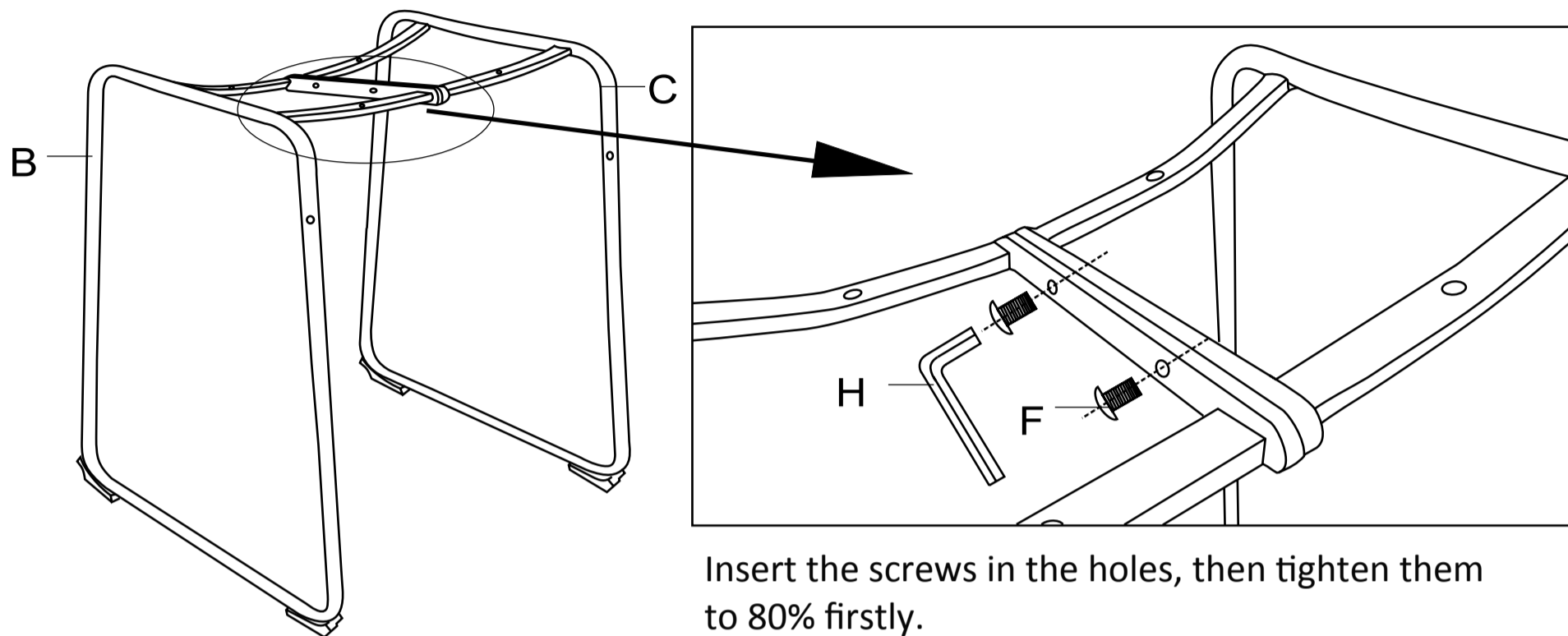

Step 2

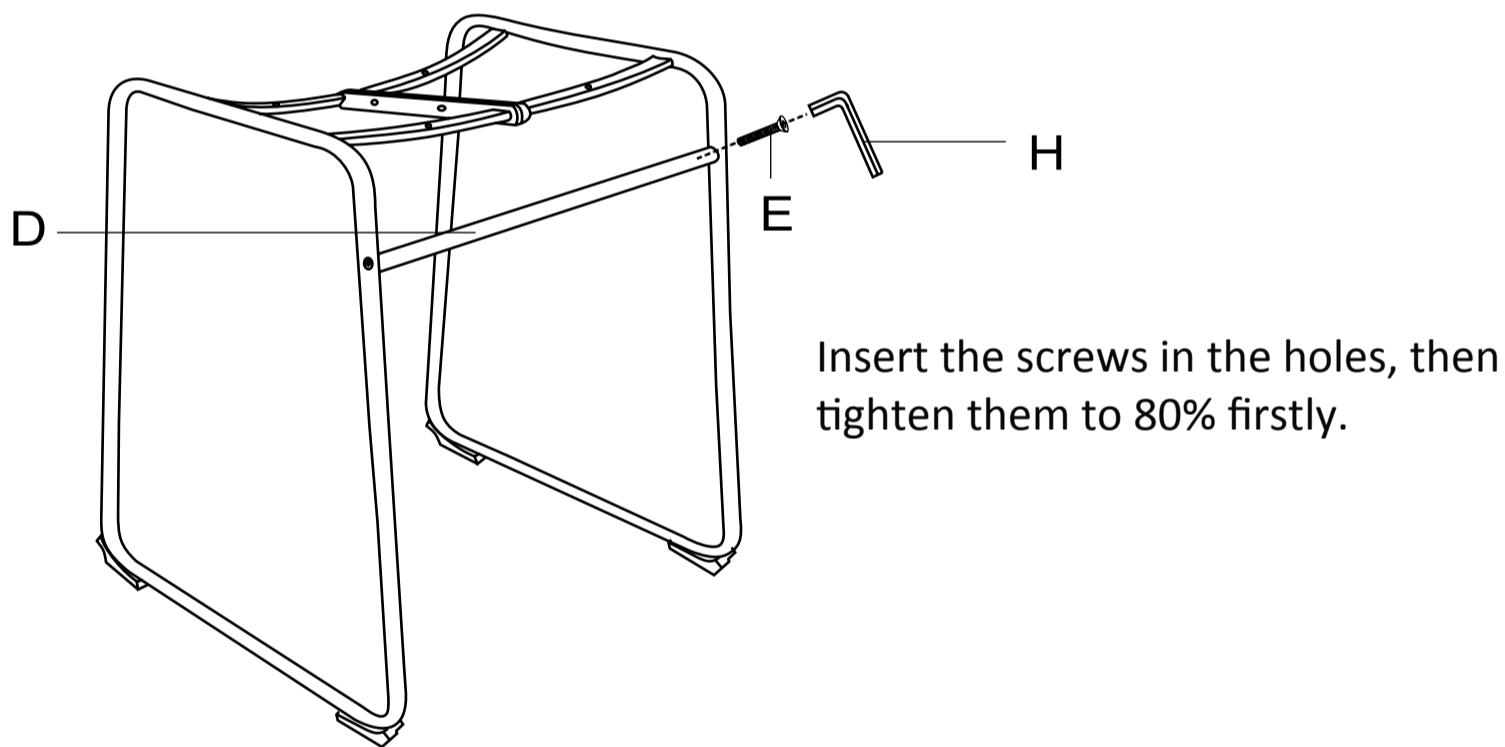

HARDWARE LIST	CODE	PARTS	QTY.	CODE	PARTS	QTY.	CODE	PARTS	QTY.
	A		1	C		1	G	M6 X 22MM	4
B		1	D		1	H	M6	1	
			E	M6 X 30MM	2				
			F	M8 X 14MM	2				

Get social with us and discover more about our products, tips and exclusive discounts!



Step 3

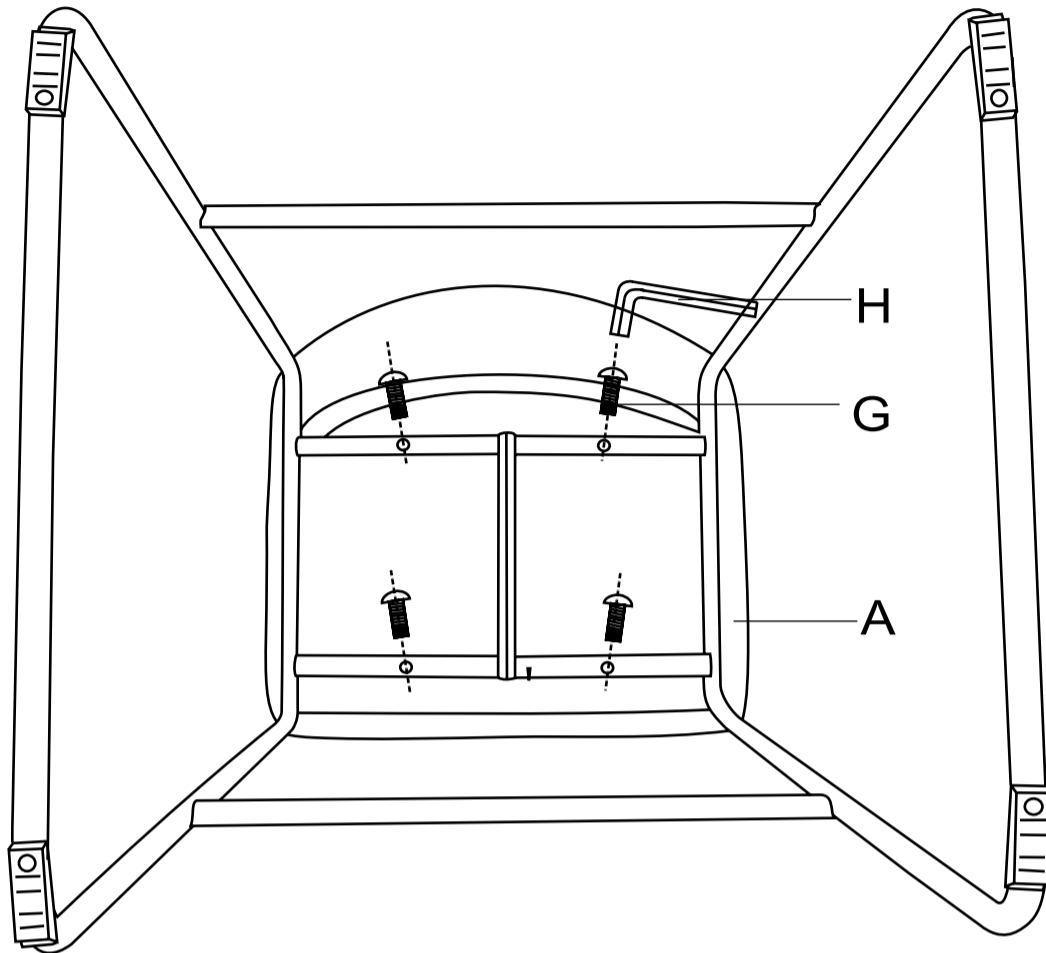

Insert the screws in the holes, then tighten them to 80% firstly.

Step 4

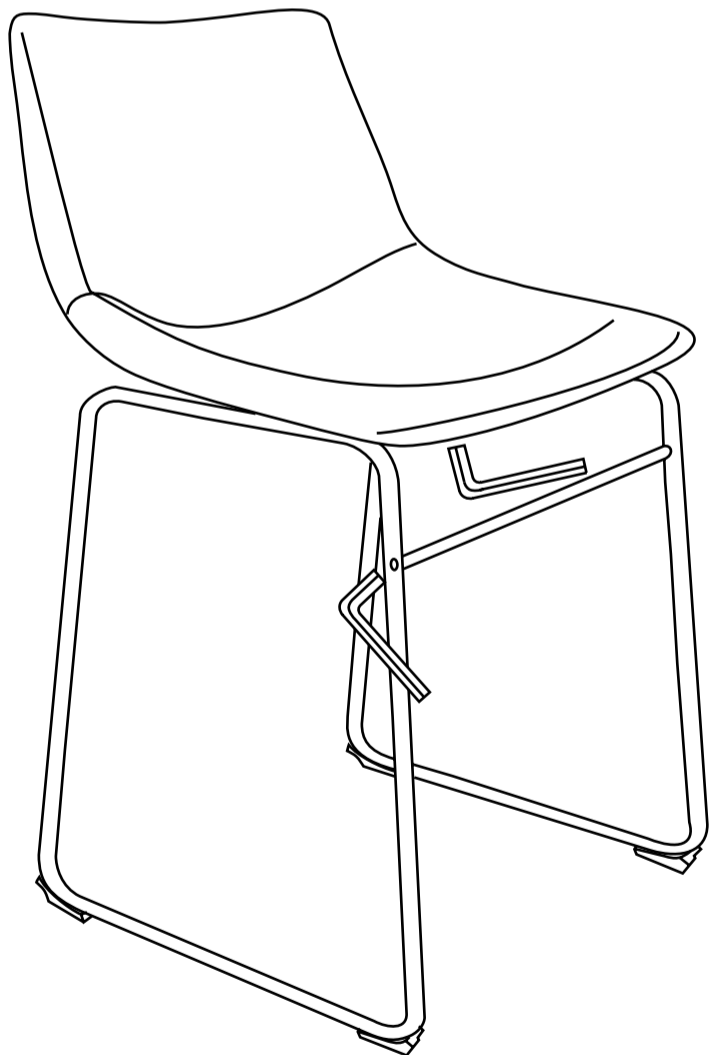

Use body weight to adjust balance of chair, then tighten all the screws to 100% all the way.

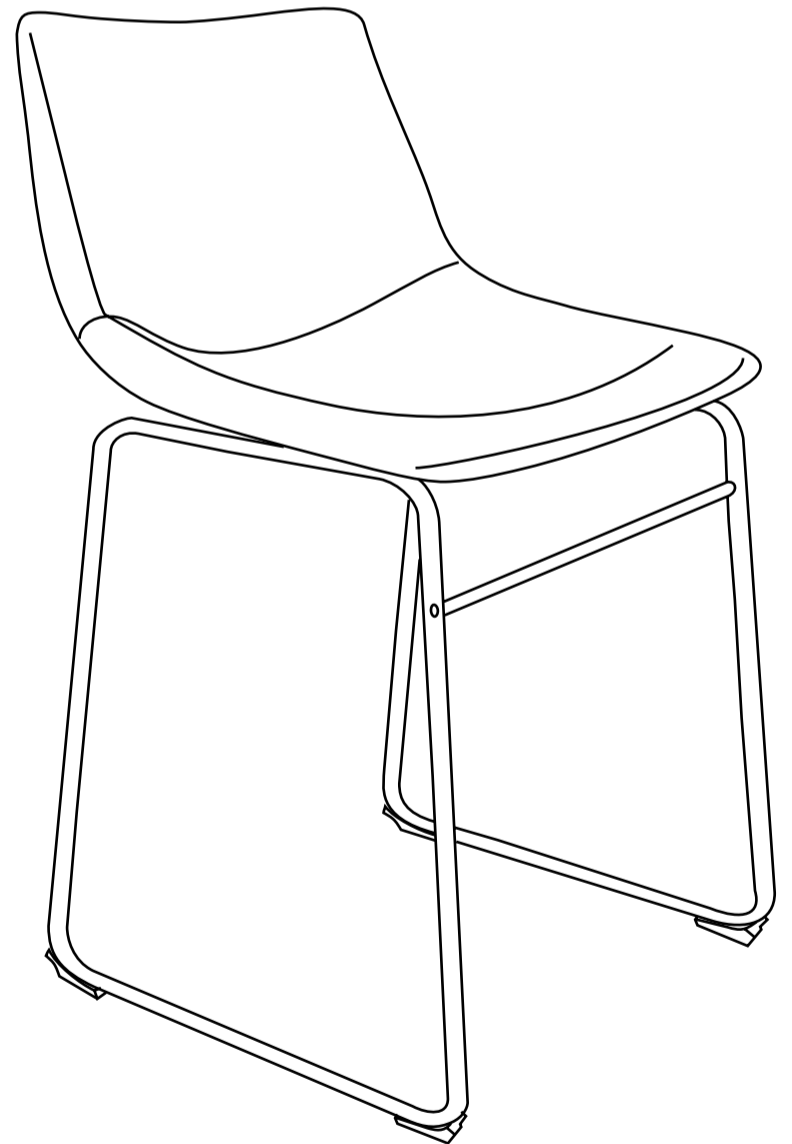

A few days after initial assembly, the product may acclimate to its new environment. Please ensure all screws are still securely tightened.

