

Assembly Instruction

DINING SIDE CHAIR

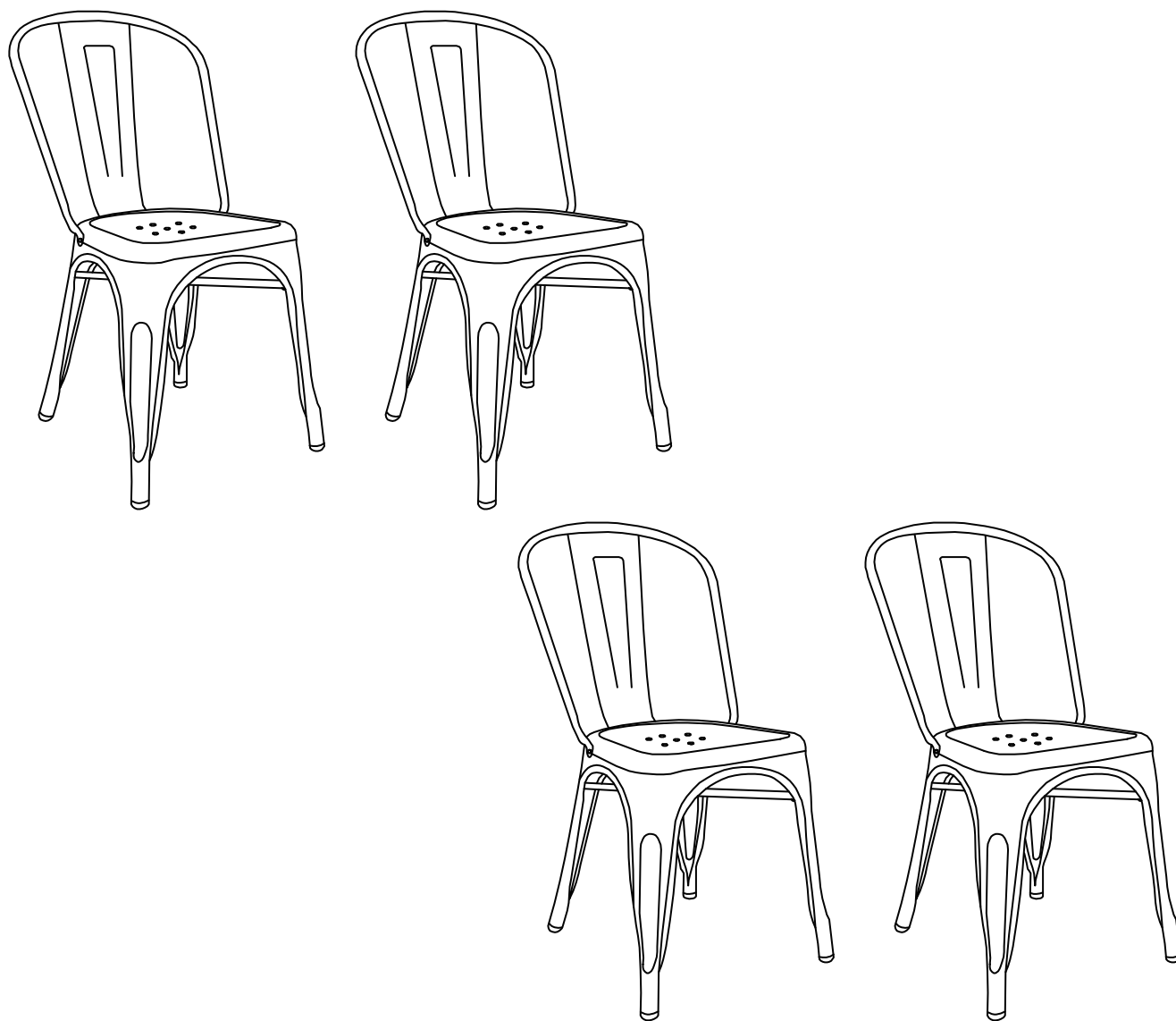



Carefully unpack and identify each component before beginning assembly. Before you begin, please refer to parts list to make sure that you have all parts. Please take care when assembling the unit and always place the parts on a clean, soft surface.

Get social with us and discover more about our products, tips and exclusive discounts!

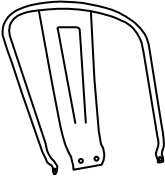

PRE-ASSEMBLY PREPARATION

- **CARE AND CLEANING:**
DO NOT scratch or chip the finish.
DO NOT use abrasive chemicals for cleaning.
- **MAINTENANCE:**
Check bolts/screws periodically and tighten them if necessary.
- **WARNING:**
DO NOT USE if this product become damaged, and/or components are broken or missing.
- **REMINDER:**
DO NOT fully tighten all bolts until assembly is completely finished.

PARTS LIST		HARDWARE LIST	
SEAT (A)	BACKREST (B)	ALLEN BOLT (C)	ALLEN WRENCH (D)
			
Qty: 4	Qty: 4	M6 x 12MM Qty: 16	Qty: 1

Attach the Backrest (B) to the Seat (A) by using Allen Bolt (C) and Allen Wrench (D).

